



**BROADBAND NETWORKS
PART 17 - SYSTEM POWERING**

By Neal McLain

This is Part 17 in a series of articles about coaxial broadband networks. In this article, we will take up a new subject: powering.

A REVIEW OF THE PIECES

Before proceeding with the discussion of powering, let's review the three types of amplifiers which make up a broadband network:

- **Line Extenders.** *Feeder* is the portion of the network which is tapped to provide the signals which are delivered to subscriber premises. *Line extenders* are amplifiers inserted into the feeder at intervals of 500 to 1000 feet, to compensate for signal losses. Because line extenders operate at fairly high output levels (typically around +46 dBmV), cascades must be severely restricted in order to control distortion. Most designs limit line extender cascades to a maximum of two amplifiers.

- **Bridger Amplifiers.** A *bridger* amplifier is used at the point where the main trunk cable is split to generate feeder lines. The output of the bridger is often split again so that one bridger can generate as many as four feeders. The bridger is frequently incorporated into the same physical housing as a trunk amplifier.

- **Trunk Amplifiers.** The *trunk* is the portion of the network which is optimized to carry signals over long distances. Trunk amplifiers, spaced at intervals of 1500 to 2000 feet, compensate for signal losses. Signal losses result from two factors: attenuation in the coaxial trunk cable itself and splitting losses which divert signal to bridging amplifiers.

(continued on page 4)

Next Meeting:

Tuesday,
December 16, 1997

**Server Technology
Considerations**

J.T. Whitney's
674 S. Whitney Way

Lunch from
11:30am - 12:30pm

**Meeting and Program
following lunch**

In This Issue:

Minutes page 2
 Amateur Radio News ... page 3
 New DTV Listserver page 7
 SBE Short Circuits page 8
 Local Legals page 9

DEFINING AN EAS WEEK

By Leonard Charles

As each station in the country begins to feel a bit of normalcy surrounding their participation in the new EAS system, and as the EAS "shake down" year comes to a close, attention is turning to vulnerability to FCC forfeitures where EAS is concerned.

One area that puzzles some stations is the consistent reception of EAS tests from monitored stations. EAS rules require that your station have records verifying that you have transmitted a weekly test each week,

and that you have received a test each week from each of the two stations you are mandated to monitor. The rules have also changed that "week" to a "7 day-24 hour per day" week. The FCC did not define that "week" in the rules and when asked for clarification says that each station is free to set that "week" as they see fit, as long as they keep it consistent. For example, if your station defines its week as Sunday through Saturday, that's OK as long as you never change that definition. If your competition sets their week as Monday through Sunday, that's OK too, as long as they don't change their definition.

This new found scheduling freedom has spawned compliance concerns. In actual real life experience, when two stations (one monitoring the other) define their week differently as noted above, there may be one or more weeks throughout the year when the monitoring station does not receive a weekly test from the station(s) it monitors. And, there may be one or more weeks when it receives two tests from one or both stations it monitors. This is far too confusing to try to explain in text but if you think about it while staring at a calendar, it is true.

(continued on page 2)

CHAPTER 24 OFFICERS

CHAIR:

Fred Sperry (Wis. Public TV)
W - 264-9806 FAX - 264-9646
fsperry@mail.state.wi.us

VICE-CHAIR:

Kevin Ruppert (WISC-TV)
W - 271-4321
kruppert@wisctv.com

SECRETARY:

Neal McLain (CTI)
W - 831-4636
nmclain@compuserve.com

TREASURER:

Stan Scharch (WISC-TV)
W - 271-4321
sscharch@wisctv.com

COMMITTEE APPOINTEES

Program Committee:

Mark Croom	271-1025
Denise Maney	277-8001
Kerry Maki	833-0047
Steve Zimmerman	274-1234

Membership and Past-Chair:

Paul Stoffel

Sustaining Membership: Fred Sperry

Strategic Planning: Dennis Behr

Special Events: Kevin Ruppert

Certification and Education:

Jim Hermanson 836-8340
Tim Trendt (UW-Platteville)

Frequency Coordination:

Tom Smith W - 263-2174
smithtc@vilas.uwex.edu

SBE National Board Member & Chapter Liaison:

Leonard Charles
W - 271-4321 FAX - 271-1709
lcharles@wisctv.com

November Business Meeting Minutes

Chapter 24 of the Society of Broadcast Engineers met on Tuesday, November 18, 1997, at Electronic Theater Controls, Inc., in Middleton, Wisconsin. There were 15 persons in attendance, including 12 members (9 certified) and three guests (two of the guests were representatives of Electronic Theater Controls, Inc. who did not sign the attendance sheet.) The meeting was chaired by Chapter 24 Chairman Fred Sperry.

Call to order: 6:30 pm. Sperry began by thanking Electronic Theater Controls for hosting the meeting. The minutes of two previous meetings were approved: the September meeting (as published in the October Newsletter) and the October meeting (as published in the November Newsletter).

Membership Report (reported by Sperry in Paul Stoffel's absence): Current Membership 67; Certified Membership 35; Newsletter Mailing Count 135.

Treasurer's Report (reported by Sperry in Stan Scharch's absence): the chapter balance is in the black.

Newsletter Editor's Report (reported Newsletter Editor Mike Norton): The deadline for the December Newsletter is midnight 12/5/97; the folding party is 5:30 pm 12/10/97 at WKOW-TV.

Sustaining Membership Report (reported by Sperry): Panasonic has recently renewed; the Chapter now has 25 sustaining members.

Program Committee (reported by Steve Zimmerman): Plans for the December program were announced.

Certification and Education (reported by Jim Hermanson): one person sat for an examination during the most recent exam period; the next exam period will take place at the NAB Convention in Spring, 1998.

Frequency Coordination Report (reported by Tom Smith): Coordination requests have been received from WJNW-TV, ESPN, and ABC.

National News (reported by Sperry): The national SBE is participating in a number of FCC proceedings; details are available at the SBE website. A new SBE publication, "Introduction to RF" is now available.

National Liaison Report: no report.

Old Business: Sperry thanked all members who assisted with the recent Broadcasters Clinic.

New Business: Sperry announced an equipment demonstration to be presented by Discrete Logic, in Milwaukee, in January.

The business meeting was adjourned at 6:40 pm. The program featured a tour of Electronic Theater Controls' manufacturing facility. ETC manufactures, installs, and services lighting instruments and lighting control systems for theatrical venues, television studios, themed environments, and architectural interiors.

Submitted by Neal McLain, Secretary

DEFINING AN EAS WEEK (continued)

The FCC EAS Office answers these concerns this way: Each station should receive two tests each week depending on the sending stations' week. If two tests are not received, a station should check why they did not receive the tests. Inspectors should ensure that (log) entries are there on a consistent basis. Even if a station has a really weird week, they should still have logs showing the sending/re-sending (RWTs/RMTs) of a test at least 50 times a year. The same applies to receiving 100 tests per year (50 each from two stations). In fact, per station totals could be up to 54 depending on year-end/year-start periods. This amounts to plenty of tests to ensure equipment readiness and documentation of station compliance.

SBE FILES 450-455 COMMENTS

By Leonard Charles

The SBE FCC Liaison Committee has prepared and filed comments on FCC Docket No. 97-214 concerning the take over of parts of the 455MHz and 459MHz Broadcast Auxiliary Services bands by the Mobile Satellite Services industry. A complete text of this filing is available on the SBE web site at <www.sbe.org>.

**Chapter 24
World Wide Web Site**
<http://www.sbe24.org>



Leonard Charles is the editor for the Electronic Version of this Newsletter uploaded monthly onto SBE Chapter 24's web page.



**NIALL
ENTERPRISES**

P.O. Box 314
Belmont, Wisconsin 53510
(608) 762-5327 John O'Neill

AMATEUR RADIO NEWS

By Tom Weeden, WJ9H

- The vanity call sign program will enter its final phase as the FCC was scheduled to open "Vanity Gate 4" on December 2. Amateurs of General, Technician Plus, Technician and Novice will be able to apply for available call signs with an application fee of \$50. Novices will only be eligible for 2x3 call signs (2 letters before the number and 3 after). Technician, Tech Plus and General class licensees will be eligible for either 1x3 or 2x3 call signs.

- The FCC has also announced on-line license renewals for certain licensees, including amateur radio operators. The new Form 900 is for renewals only and cannot be used to modify a license or to renew an expired license. Form 900 can only be accessed within 120 days of the expiration date of the license. Form 900 is found on the FCC's Wireless Telecommunications Bureau's Electronic Commerce page on the internet at www.fcc.gov/wtb/electcom.html.

(Excerpts from December 1997 "QST" Magazine)

UPCOMING PROGRAMS PLANNED

The tentative outline for future SBE Meeting Program topics has been compiled by the Chapter 24 Program Committee. They are as follows:

Day/Date	Topic
Wednesday 12/17/97	Server Technology Considerations
Thursday 1/22/98	Radio Station Automation
Tuesday 2/17/98	Test and Measurement Equipment
Wednesday 3/18/98	ATM Technology or Related Topic
Thursday 4/16/98	Elections and NAB Review
Tuesday 5/19/98	Telephone Company Tour
Wednesday 6/17/98	Sullivan NOAA Weather Office Tour

If you have any suggestions for program topics you'd like to see, please contact one of the Chapter 24 Program Committee Members.

James (Jim) B. Rogers 
Western Regional Sales Manager
(619) 748-2151
Fax: (619) 748-1879
Pager: (800) 970-3239
E-mail: jrogers@comarkcom.com
JBR.COM@worldnet.att.net

 **COMARK**
a THOMCAST Company
12612 Arabian Way • Poway, CA 92064 U.S.A.
<http://www.comarkcom.com>



FOX 47
WMSN MADISON
A SULLIVAN BROADCASTING STATION

7847 BIG SKY DRIVE
MADISON, WISCONSIN 53719
(608)833-0047 • FAX(608)833-5055

 **HEWLETT
PACKARD**

Jon S. Gedymin
Video Sales Manager
Midwest Region

Hewlett-Packard Company
250 North Patrick Boulevard, Suite 100
Brookfield, Wisconsin 53045-9945

800/477-6111 Ext. 2263
Fax 414/569-0966
Internet_jon_gedymin@hp.com

Panasonic
Broadcast & Television Systems Company



HERB VAN DRIEL
Direct Sales Manager
Entertainment Systems Division

Atlanta 1996
The Official Broadcast
Equipment of the
1996 Olympic Games.

1707 N Randall Road
E-Zip: 1-C-3 WI Tel: 608.355.0662 HQ Tel: 847.468.5160
Elgin, IL 61023 WI FAX: 608.355.0663 HQ Fax: 847.468.5161

Division of Matsushita Electric Corporation of America

Broadband Networks Part Seventeen (continued)

In the early days of the cable television industry, each amplifier contained a DC power supply designed to operate from a 115-volt supply. Power was obtained from the local power utility to operate the amplifiers.

As the cable television industry grew during the 50s and 60s, cable manufacturers began making "hard cables" constructed with solid aluminum shields and copper (or copper-clad aluminum) center conductors. Although these cables were originally developed to provide low attenuation at RF, they also offered a side benefit: very low DC resistance.

DC resistance values are typically specified in ohms per 1000 feet of "loop" resistance: i.e., the total resistance of shield plus the center conductor. Typical DC loop-resistance values are:

Cable Trade Size	DC Loop Resistance OHMS/1000 FEET
0.500	0.172
0.750	0.076
1.000	0.040

LINE POWERING

The availability of cables with low DC loop resistances opened the door to "line powering." This technique allows amplifier power to be distributed

over the same cable that carries the signal.

Figure 1 shows a typical line-powering situation. A centrally-located power supply provides power for the surrounding "zone" of amplifiers; in this example, it provides power for nine trunk amplifiers and their tributary line extenders. Note that:

- "Power blocks" isolate each power supply zone from adjacent zones. Amplifiers in adjacent zones are powered from other power supplies. Although shown as discrete components, power blocks are usually incorporated into amplifier housings.
- The direction of power flow is not necessarily the same as the direction of RF signal flow. Thus, some portions of the network may pass power in one direction and RF in the opposite direction. In the Figure 1 example, the two amplifiers east of the power supply receive power through their output ports even though the RF signal is flowing west.

Line powering dramatically reduces the number of locations where power must be obtained from the electric power utility. In the Figure 1 example, there are nine trunk amplifiers and 36 line extenders — a total of 45 amplifiers. If each amplifier required an individual

utility-power connection, 45 power connections would be needed. Some utility companies (including WPL) would require a separate electric meter for each connection, resulting in 45 monthly electric bills, each with a separate "customer charge," the basic monthly charge imposed on each customer for meter rental, meter reading, and billing.

POWER SUPPLIES

A power supply is essentially a stepdown transformer: it accepts 115 volts at its primary and steps it down to the operating voltage required by the amplifiers:

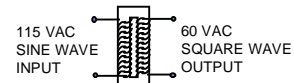

The first line-powered cable TV amplifiers operated at 30 volts, although most cable TV amplifiers now operate at 60 volts. In the past few years, 90-volt amplifiers have been introduced. Higher voltages permit more efficient distribution: for a given power load, a higher voltage means lower current, and hence, lower I²R loss in the cable.

The transformer is a "ferroresonant" type, which essentially means that there's not enough iron in the core, so
(continued on next page)

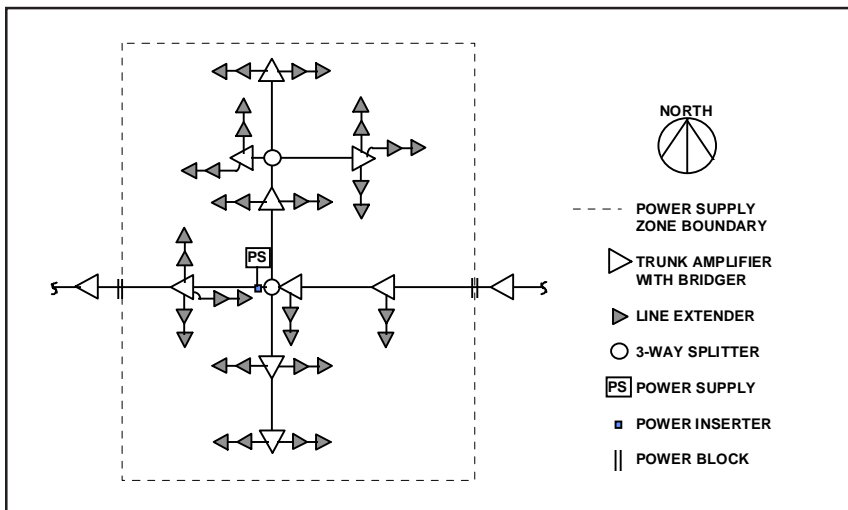

FIGURE 1. A typical power supply zone. The RF signal enters the zone from the east, passes through the zone, and passes on to the next zone to the west. The power supply near the central node generates a 60-volt AC square wave which powers all amplifiers in the zone. Note that the east trunk leg carries power and RF in opposite directions.

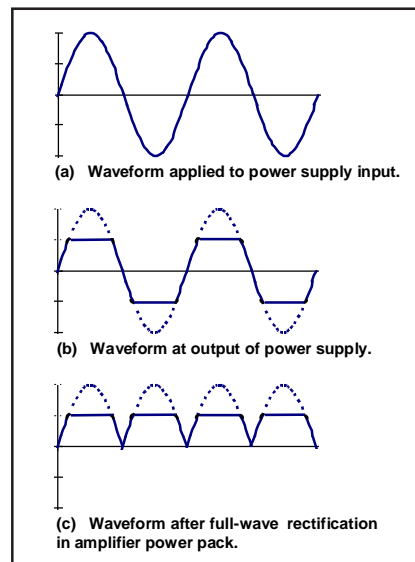

FIGURE 2. Typical power supply waveforms.

Broadband Networks Part Seventeen (continued)

the core saturates on voltage peaks. Once it saturates, the output voltage remains more-or-less constant, independent of the input voltage. As a result, the output of the power supply is a somewhat rounded square wave (Figure 2).

I'm not quite sure how or why this technique originated, but it offers a number of advantages:

- At any given voltage, a square wave can transfer more power than a sine wave.
- The ferroresonant transformer output voltage remains essentially constant over a fairly wide range of input voltages. Thus, the power supply acts as a voltage regulator, absorbing voltage spikes and sags.

- The amplifier's DC power supply (usually called a "power pack") requires less filtering. Each individual amplifier contains a power pack which converts the incoming 60-volt AC to 24 volts DC. Like most other DC power supplies, the power pack includes a full-wave rectifier. If the rectifier input is a square wave, the output is already close to DC, and requires less filtering to achieve ripple-free performance (Figure 2).

POWER SUPPLY LOCATIONS

Power supplies are installed throughout the distribution system. In a typical broadband network, one power supply is required for every eight to ten trunk amplifiers. If there is a high ratio of line extenders to trunk amplifiers, a higher number of power supplies may be required.

Power supplies can be installed on utility poles, in pedestals, or inside buildings. Figure 3 shows a typical pole-mounted supply; note the electric meter

and disconnect switch just below it.

Two rules dictate the number and location of power supplies:

- Total current load. A typical power supply is rated at 15 amperes at 60 volts. The total current load drawn by all amplifiers cannot exceed the manufacturer's capacity rating.
- IR drop. Ohm's Law applies: the farther an amplifier is from the power supply, the lower the voltage it receives from the power supply. Most amplifiers are designed to operate satisfactorily on any input voltage from 45 to 60; however, if the input voltage drops much below 45, the amplifier's DC power pack cannot regulate properly.

CURRENT CALCULATIONS

When a new broadband network is designed, the designer attempts to



FIGURE 3. Typical pole-mounted power supply. Electric power, at 115 volts, is obtain from the power company's utility.

minimize the total number of power supplies while still assuring that the two placement rules - total current load and IR drop - are not violated. At first glance, this might seem like a fairly easy assignment - after all, it's just a bunch of Ohm's law calculations. But the actual calculations can get very tricky.

To illustrate how this works, let's take a small portion of the Figure 1 example and work through the calculations. We begin by taking a close look at the power supply and the equipment immediately adjacent to it:

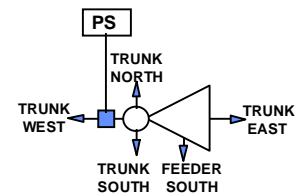

Here we have:

- The power supply itself.
- The power inserter, a device which couples the AC output of the power supply onto the trunk cable without distorting or disrupting the RF signal flowing in the trunk.
- A 3-way splitter (which might actually be two 2-way splitters). This splitter is at the center of the power supply zone; from this point, AC power flows to amplifiers in all four directions.
- A trunk/bridger amplifier. This amplifier performs two functions: it amplifies the trunk signal and it generates the feeder line which heads south.

In an actual network, all of these components would probably be located at the same physical point: either on

(continued on page 6)

L O U T H
A U T O M A T I O N

Kurt Schini
Central Regional Sales Manager

7402 Timberlake Trail, Suite 204, Madison, WI 53719
(608) 277-0702 FAX (608) 277-0706
e-mail 105224.2131@compuserve.com

SONY **Kevin Peckham**
Account Manager
Broadcast Products Division

Sony Communications Products Company
1200 North Arlington Heights Road
Itasca, Illinois 60143
Telephone (608) 271-3778
(708) 773-6046

Service Center (708) 773-6037
Emer. Tech. Assist. (201) 833-9533
National Parts Center (800) 538-7550

WISC-TV
CBS

MADISON

3

Broadband Networks Part Seventeen (continued)

the same utility pole or in the same pedestal. From the standpoint of the 60-volt AC signal generated by the power supply, this entire collection of components can be assumed to have zero resistance; thus, we can assume that the full 60 volts is heading away in all four directions.

Thus, for the purposes of IR drop calculations, we can split the problem into four separate problems, and make a separate calculation for each of the four trunk cables, or "legs," which leave this power supply. For this illustration, we'll pick the leg which heads east. In this direction, there are only three amplifiers: a trunk amplifier and two line extenders:

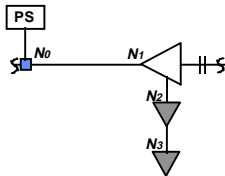

We identify each amplifier by "node" number N0, N1, etc.

From the standpoint of the AC voltage, we can draw an equivalent circuit as follows:

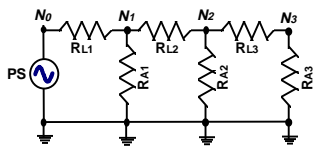

In this diagram, we represent cable and the amplifier power packs as resistors identified as follows:

- RL = Loop resistance of the cable. This figure is the total resistance of the center conductor plus the shield.

- RA = Resistance of the amplifier power pack. We temporarily assume that the power pack acts like a resistor.

Note that the common terminals of all amplifiers are grounded, and that all three grounds are connected together through the cable shield. This reflects the fact that the amplifiers actually are (or should be) physically grounded.

But this does not mean that we can ignore the resistance of the shield (which we might be tempted to do because it might allow us to use a lower loop resistance value). Even in wet soil, the resistance between two ground rods spaced 1000 feet is likely to be several ohms - substantially more than the resistance of the coaxial shield itself. Furthermore, current flowing in nearby power lines may cause the ground potential at the two points to differ by several volts (this is the so-called "stray voltage," the source of much contention between power companies and dairy farmers).

So, for purposes of DC calculations, we have to use the full loop resistance values.

We can now assign actual values to the resistances:

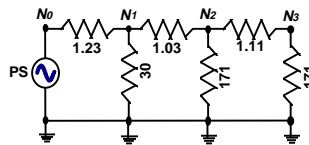

The cable resistances shown in this diagram were taken from an actual design located in Oshkosh; the amplifier resistances are based on Jerrold SX-series equipment when operating at 60 volts.

With this information, we now determine the voltages at Nodes N1, N2, and N3 to ensure that the input voltage at each amplifier does not fall below the minimum permissible voltage (45 volts).

Now this looks like a straightforward problem: it's just a bunch of resistors in a series/parallel combination. Anybody with basic electronics training should be able to make the necessary calculations and come up with the following results:

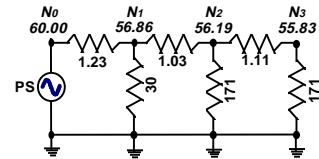

Unfortunately, it's not that easy: amplifier power packs do not act like pure resistors. Indeed, they do just the opposite: they draw more current when the input voltage drops. In this respect, they act just like any other regulated DC power supplies: they are constant power devices, and they draw more current when the input voltage drops.

Of course, as soon as a power pack starts drawing more current, the voltage drops even further because of the increased IR drop in the cable. So then the power pack draws more current, the voltage drops further, the power pack draws more current, and so on, ad infinitum.

Or at least for a second or two. In an actual network, this process reaches an equilibrium very quickly.

So how do we calculate what the equilibrium node voltages will be?

The most common technique is an iterative approach. We note that the Node Voltages at N1, N2, and N3 are no longer 60 volts; therefore we know that the power packs in the three amplifiers are drawing more current than they were during the first iteration of calculations. In effect, their resistances have *decreased*. We consult the

(continued on next page)

JAMES F. DOHERTY
Traffic Supervisor
Satellite & Video Services

Norlight
TELECOMMUNICATIONS

275 NORTH CORPORATE DRIVE
BROOKFIELD, WI 53045-5818
414.792.7708 Fax: 414.792.7717
e-mail: jfd@norlight.com

CTI

<http://www.CTIinfo.com>
email - cti@CTIinfo.com
Phone - 608-831-4636
Fax - 608-836-1840

VCR Controllers
Character Generators
Satellite Antenna Controllers
Broadcast / Cable Television Consulting

John W. Crooks
Site Installation Manager

BCS Wireless

608-527-5670 ph.
P.O. Box 730
New Glarus, WI 53574-0730
johnc@bcswireless.com
fax: 608-527-5674

Broadband Networks Part Seventeen (conclusion)

amplifier manufacturer's published specifications to determine the new resistance values:

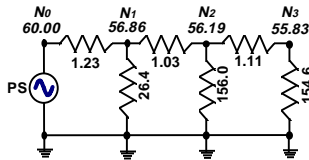

We now repeat the node-voltage calculation using the new resistance values. This time around, we get:

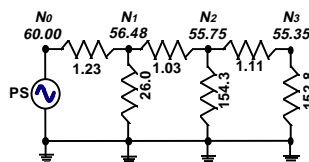

Then we do it again. And again. We continue this process until the difference between successive sets of values becomes infinitesimally small.

In this example, the node voltages stabilize to less than 0.01 volt after just seven iterations:

N1	N2	N3
60.00	60.00	60.00
56.86	56.19	55.83
56.48	55.75	55.35
56.44	55.69	55.29
56.43	55.69	55.28
56.43	55.68	55.28
56.43	55.68	55.28

We can tell by inspecting these results that the worst-case node voltage does not drop below 45 volts. So the design passes this test.

Last of all, we calculate the total current drawn by all amplifiers. Again referring to the manufacturer's published specifications, we determine the current drawn by each device *at its equilibrium node voltage*, and simply add them up. In this case:

	N1	N2	N3
V	56.43	55.68	55.28
I	2.18	0.36	0.36

so the total current heading east from the power supply is about 2.9 amperes.

So now we've completed the calculations for one of the four trunk legs leaving the power supply. Next, we repeat the process for each of the other three legs.

We immediately notice, however, that the other three legs are a lot more complicated. Indeed they are: I selected the easy leg for the example. But the process is still the same: calculate the total resistances to each node, calculate the node voltages, determine new amplifier resistance values from the manufacturer's specifications, and then repeat the process. Keep repeating it until successive calculations produce insignificant changes. The whole process rarely requires more than a dozen iterations.

But the process can still take a long time simply because of the large number of calculations which must be performed during each iteration. Ten years ago, when I was working for Warner in Oshkosh, we had one of the early IBM PCs. We'd always set up power-supply calculations at the end of the day so the PC could run all night.

Next month we'll continue with the discussion of powering.

DTV LISTSERVE AVAILABLE

If you have an e-mail account, Broadcast.Net has added a new list to their BNet server that you may want to join.

DTV - Is a discussion forum for those involved in the conversion to Digital Television. It will encompass both studio and transmitter migration to digital. Lets share our problems, solutions and opinions and we ALL will be better prepared for the obstacles ahead.

To subscribe, send e-mail to: majordomo@broadcast.net
In the body of your e-mail message type: subscribe dtv
The listserve program will respond with instructions on how to post to the list.

FCC PROPOSES AUCTIONS FOR BROADCAST

By Tom Smith

In action at the November, 25th meeting, the FCC adopted a Notice of Rulemaking to allow for auctions to be used to choose from competing applicants for new analog TV and radio licenses. This action is a result of a directive from Congress. The reason for the auction proposal is that there are 1,245 radio and 462 applications pending, and due to court actions that declared the criteria for determining winning applicants was illegal. This action would affect applications that were filed after the 1993 court action. Applicants that file before July 1, 1997 would have until February 1st to settle competing claims or face auction. Applicants after July 1st will required to go to auction.

This action also request comments on the use of auctions for noncommercial Instructional Television Fixed Service stations (ITFS). The FCC also placed a freeze on all applications for new broadcast TV and radio stations.

Comments from Commissioners Michael Powell and Gloria Tristani raised concerns about minority and women ownership and the use of bidding credits. Chairman William Kennard expressed concern over the consolidation of the broadcast industry and how it affected minorities and women. All Commissioners stated that they felt that auctions would speed up the licensing processing.

The auctions may start in late 1998.

Compiled from BROADCASTING & CABLE and C-SPAN

The Chapter 24 Newsletter is published monthly. Submissions of interest to the broadcast technical community are welcome. You can email your articles to:

Mike_Norton@wetrn.pbs.org
or send them to:
SBE Chapter 24 Newsletter Editor
5174 Anton Dr. #15
Madison, WI 53719-4201

SBE's Short Circuits - December 1997

By John L. Poray, CAE, Executive Director

FROM THE SBE FCC LIAISON COMMITTEE

Many broadcast engineers are deeply concerned about FCC Engineering Technology (ET) Docket 97-214, regarding the FCC's proposal to amend Part 2 of its Rules to allocate the 455-456 MHz RPU band to the Mobile Satellite Services.

The SBE FCC Liaison Committee has now completed a second draft of detailed comments to this matter. These comments will clearly express to the FCC the very grave concerns of the broadcast engineering community any potential damage to the 455-456 MHz RPU band. These Comments are being written by engineers on the SBE FCC Liaison Committee that go back to the roots of the SBE's deep interest in Part 74 coordination interests—almost 20 years now.

As soon as these comments are approved by the SBE Board and filed, they will be posted on the SBE Web Site. The deadline to file Comments is December 1, 1997. rest assured that SBE is well ahead of schedule on this vital project and will keep our members informed. Dane Ericksen, P.E., CSRE, CSTE Chairman, SBE FCC Liaison Committee

NEW SBE "INTRODUCTION TO DTV RF" BOOK AVAILABLE

Pre-publication orders are now being accepted for the new SBE publication, "Introduction To DTV RF," written by Douglas W. Garlinger, CPBE, Director of Engineering for LeSea Broadcasting Corporation.

Pre-publication orders will be

accepted through December 31, 1997 at a special price for SBE members of \$39 and \$49 for non-members, plus \$2.00 for shipping. To order, call the SBE National Office at (317) 253-1640. You may fax your request to SBE at (317) 253-0418. Payment by credit card or check must accompany orders. Send mail orders to: DTV RF, Society of Broadcast Engineers, 8445 Keystone Crossing, Suite 140, Indianapolis, IN 46240.

YOUTH MEMBERSHIP CATEGORY PROPOSED

At the September 25 meeting of the SBE Board of Directors, a proposal was introduced by Membership Chairman Robert Hess outlining a program that would involve high school-aged youth in SBE for the first time. The goal is to educate young people about broadcast engineering and careers in the field with the hope that it will help stimulate the flow of young people into broadcast engineering.

By offering high school age students Youth Membership in SBE, the Society can provide information and resources to help develop interest, enthusiasm and knowledge in the science and art of broadcast engineering, and thereby, increase the number of students who go into post-secondary education with interest in entering broadcasting's technical fields. More details are about the Youth Membership proposal are in an article in the November/December issue of the SBE SIGNAL.

The SBE Board of Directors would like to receive written comments and ideas from you about the Youth Membership proposal. E-mail your comments to John Poray at jporay@sbe.org or mail them to Youth Membership, SBE, 8445 Keystone Crossing, Ste. 140, Indianapolis, IN

46240. The Membership Committee will review all comments and make a recommendation to the Board for action during its April 1998 meeting in Las Vegas. If approved, the program could begin as early as September of 1998.

SBE MEMBERS GET DISCOUNT FOR NAB'98

Members of the Society of Broadcast Engineers can save up \$300 on the Conference Registration for NAB'98 in Las Vegas. SBE members get the NAB member rate. Check the appropriate member box on the NAB'98 registration form.

NAB'98 is April 4-9 at the Las Vegas Convention Center and Sands Convention Center. April 4 will be special workshops and tutorials, including the "Radio Bootcamp," presented by SBE's Ennes Educational Foundation Trust. The exhibit floor will open on Monday, April 6.

30th LEADER SKILLS SEMINAR SCHEDULED FOR JUNE 8-12, 1998

SBE will sponsor the 30th Leader Skills Seminar, presented by Richard Cupka, June 8-12, 1998 in Indianapolis. This will be the second consecutive year SBE has sponsored this program, designed to teach leadership and management skills to broadcast engineers. The course was presented by NAB for 28 years, before being dropped around 1991.

The seminar will be held at the Indianapolis Quality Inn South, which provides free airport shuttle, full service restaurant, recreational facilities and convenient location along Indianapolis' beltway.

The cost for this intensive program

(continued on next page)



5727 Tokay Boulevard
Madison, Wisconsin 53719
(608) 274-1234
Fax: (608) 274-9514



SCHARCH ELECTRONICS CO.
Small Business Communications
1105 Middleton Street
MADISON, WI 53717-1078
(608) 831-2266 (800) 831-2266



David Thormodsgaard
Broadcast Sales Engineer
thor@alphavideo.com
Pager # (800) 236-0034
Pin 12462
(800) 388-0008
7711 Computer Avenue
Edina, MN 55435
(612) 896-9898
FAX (612) 896-9899

LOCAL LEGALS

Compiled by Tom Smith

PROPOSED

WKCH(FM) Whitewater, WI

Goetz Broadcasting Corp. seeks to purchase 51% of the construction permit from Scott M. Tretadue for \$34,718.69. Goetz Broadcasting owns WFAW(AM) and WSJY(FM) in Fort Atkinson, WDLB(AM) and WLJY(FM) in Marshfield and WOSQ(FM) in Spencer. WKCH is licensed for 6 kW at 106.5 Mhz with antenna at 328 feet. Station is currently dark.

WJNW(TV) Janesville, WI

Harish Puri has applied to change construction permit to specify another antenna. Filed on October 30, 1997

**New Noncommercial FM,
Random Lake, WI**

The Wisconsin Educational Communications Board seeks to construct a new noncommercial FM at Random Lake. The transmitter would be located in Scott and would operate on 91.3 mhz with 2.6 kw at 128.5 meters. Filed on October 16, 1997

WKOW-DT Madison, WI

Shockley Communications Corp. has filed for permission to construct a new digital TV station on Channel 26 with an average power of 218.5 kw. Transmitter site is at the Madison Community Tower. Announced on December 2, 1997

Compiled from BROADCASTING & CABLE

**Short Circuits
(continued)**

is just \$650, far below similar programs. The fee includes all instruction materials and refreshment breaks each day. Food, lodging and transportation are additional. The nightly rate at the Quality Inn South is just \$69 plus 11% tax.

To register, call the SBE National Office at (317) 253-1640 or request a registration form by e-mail to John Poray at jporay@sbe.org.

**1997 MEMBERSHIP DIRECTORY
RELEASED**

Members should have received their copy of the "1997 SBE Membership Directory and Buyer's Guide" in the

mail in the last few weeks. The Directory provides a handy way for you to identify and locate other SBE members when you need them. Members are listed alphabetically and geographically by state and chapter. Sustaining Members are also listed alphabetically and in a easy to use classified section by product or service. The SBE Membership Directory and Buyer's Guide is available only to members.

**CHAPTER 24
SUSTAINING
MEMBERS**

RECENT RENEWALS:

**CTI
Norlight Telecommunications**

**THANKS TO ALL OUR
SUSTAINING MEMBERS:**

- Alpha Video
- BCS Wireless
- Clark Wire and Cable
- Comark Communications
- Fuji Film
- Harris Corporation
- Hewlett-Packard
- Louth Automation
- maney-logic
- Niall Enterprises
- Panasonic Broadcast
- Richardson Electronics
- Roscor Wisconsin
- Scharch Electronics
- Skyline Communications
- Sony Broadcast
- Tektronix
- Teleport Minnesota
- Video Images
- WISC-TV 3
- WKOW-TV 27
- WMSN-TV 47
- WMTV-TV 15

Thomas Sibenaller
Sales Representative

Roscor Wisconsin
2610 Van Loon Road
La Crosse, WI 54601
Phone: 608-784-6702
FAX: 608-785-0505
e-mail: sales@roscor.com

1965 West Ridge Rd.
P.O. Box 51
Cottage Grove, WI 53527
608 / 839-4075
FAX: 608 / 839-4985

RICHARD H. WOOD
President

TOWERS • ANTENNAS
CONSTRUCTION • MAINTENANCE

**Richardson
Electronics, Ltd.**

Becky Hilborn
Broadcast Sales
Specialist

40W267 Keslinger Road
LaFox, IL 60147 USA

Phone: (800) 348-5580
(630) 208-2372
FAX: (630) 208-2450
email: becky@rell.com
WWW: http://www.rell.com

**Your Tube and
Broadcast Component
Source.**

FUJI FILM

MAGNETIC MARKETS DIVISION
PROFESSIONAL PRODUCTS GROUP

Jerry Van Vliet
Account Representative

FUJI PHOTO FILM U.S.A., INC.
1285 Hamilton Parkway
Itasca, IL 60143
630-773-7200 Ext. 7293 • 800-877-0555 Ext. 7293
Fax 630-773-6266 • Fuji Voice Mail 800-736-3600 Ext. 7293

Milwaukee
Madison
Chicago
Indianapolis

**VIDEO
IMAGES**

Bob Marek
Account Executive

Video Images, Inc.
2137 S. Stoughton Road • Madison, WI 53716
Phone: (608) 221-8888 • FAX: (608) 221-9252
Internet: http://www.videoimages.com/



Society of Broadcast Engineers, Inc.
 8445 Keystone Crossing
 Suite 140
 Indianapolis, IN 46240



Office (317) 253-1640
 Fax (317) 253-0418
 Job Line (317) 253-0474
<http://www.sbe.org>



HARRIS CORPORATION
BROADCAST DIVISION
 District Sales Office:
 1913 Fair Oak Road
 Naperville, IL 60605

Tom Harle
 DISTRICT SALES MANAGER
 RADIO

TEL: 708-420-8899
 FAX: 708-420-9171

e-mail: tharle@harris.com
 Sales: 800-622-0022



PHONE 608-274-1515
 FAX 608-271-5193

615 FORWARD DRIVE
 MADISON, WI 53711

WORKING FOR YOU!
www.nbc15.com feedback@nbc15.com



RS-422 Remote Control

REW FFWD STOP STBY REC PLAY

Terminal Block for switches and lamps



608-277-8001
 maney-logic

Steve Olson Tektronix, Inc.
 Account Manager **Video and Networking Division**
 515 West Algonquin Road
 Arlington Heights, Illinois 60005
 E Mail: stephen.olson@tek.com
 503 305-8488 Voice Mail

847 734-6789 414 425-8050 Office
 847 364-7582 Fax 414 425-8537 Fax





1355 Armour Blvd.
 Mundelein, IL 60060-4401

Fax: 847-949-9595 847-949-9944
 E-Mail: sales@clarkwc.com 1-800-222-5348
 URL Address: <http://www.clarkwc.com> 1-800-CABLE IT



Mark Durenberger
 General Manager 90 South 11th Street
 Minneapolis, MN 55403

Office (612) 330-2433
 Fax (612) 330-2603
 e-mail
durenberger@teleportmn.com

SBE Chapter 24 Newsletter
 5174 Anton Drive #15
 Madison, WI 53719-4201



FIRST CLASS MAIL

Newsletter edited on Pagemaker 5.0 by: Mike Norton
 Contributors this month: Leonard Charles, Neal McLain, Tom Smith, and Tom Weeden.
 Thanks to Chris Cain for his work on the Chapter 24 WWW page.

© 1997 by SBE Chapter 24. Views expressed herein do not necessarily reflect the official positions of the Society, its officers, or its members. SBE Chapter 24 regrets, but is not liable for, any omissions or errors. The Chapter 24 Newsletter is published twelve times per year. Other SBE Chapters are permitted to use excerpts if attributed to the original author, sources, and SBE Chapter 24.

DECEMBER MEETING and PROGRAM



**Society of Broadcast Engineers
CHAPTER 24 MADISON, WISCONSIN
Tuesday, December 16, 1997**

Server Technology Considerations

This month's meeting will be presented by Tom Sibenaller, Sales Representative with ROSCOR WISCONSIN. Tom will discuss server technological considerations. Lunch will be from 11:30am to 12:30 at J. T. Whitney's, followed by a brief business meeting before the program.

\$8.25 lunch price includes: menu item, non-alcoholic beverage, tip and tax. Your RSVP is required by December 14. Please contact Denise Maney at: 608-277-8001 tel/fax or e-mail to: sloop26@aol.com

**J. T. Whitney's
647 S. Whitney Way
(in meeting room)**

Visitors and guests are welcome at all our SBE meetings!

1998 UPCOMING MEETING/PROGRAM DATES:

Day	Date	Program
Thursday	January 22	Review of WOLX Tower Collapse
Tuesday	February 17	Test and Measurement Equipment
Wednesday	March 18	ATM Technology

Program Committee:

Kerry Maki
833-0047

Denise Maney
277-8001

Steve Zimmerman
274-1234

Mark Croom
271-1025