



## **BROADBAND NETWORKS**

### **PART 20 - A CLOSE-UP LOOK AT TRUNK AMPLIFIERS**

*By Neal McLain*

This is Part 20 in a series of articles about coaxial broadband networks. In recent articles, we've discussed several of the requirements imposed on trunk amplifiers. In this article, we'll take a closer look at the way trunk amplifiers are constructed.

#### **AMPLIFIER PLACEMENT**

In previous articles we've noted that a cascade of trunk amplifiers operates at "unity gain": the gain of every amplifier equals the signal loss in the subsequent span of cable. Figure 1 illustrates an ideal trunk cascade: the gain of each amplifier is 25 dB, and the signal loss in each span of cable is also 25 dB.

Signal loss between amplifiers dictates the physical spacing between amplifiers. If we assume that the highest frequency being carried on the network is 402 MHz (Channel 53), the cable attenuation is about 1.07 dB per 100 feet. If we further assume that the entire loss is attributable to cable attenuation, the distance between amplifiers must not exceed  $25/1.07 \times 100 = 2336$  feet.

From this information, it should be a simple matter to place amplifiers: we simply place them every 2336 feet.

Unfortunately, it isn't this easy. Figure 2, although hypothetical, is fairly typical of the real-world situation. Note that no two amplifiers are spaced at the ideal spacing: they are either "shortspaced" or "overspaced":

- Shortspaced amplifiers are placed closer together than ideal; consequently, the signal level arriving at the input to the downstream amplifier is excessive. The gain of the amplifier can be adjusted to compensate for this extra signal. We'll

(continued on page 4)

## **Next Meeting:**

**Thursday,  
April 16, 1998**

### **Elections and NAB Review**

**Wisconsin Public  
Broadcasting Center  
3319 W. Beltline Hwy  
(ECB Board Room)**

**Dinner at 6:00pm**

**Meeting & Program  
at 7:00pm**

## **In This Issue:**

Minutes .....	page 2
Amateur Radio News ...	page 3
EAS Update .....	page 7
FCC Rulemakings .....	page 8
Telecom News .....	page 10

## **IS LOW-POWER FM NEXT?**

*By Tom Smith*

The FCC is considering three petitions that ask that a low power FM service be created. The FCC has opened a comment period on the three petitions and has posted copies of the petitions in the Mass Media section on their web site.

The first petition the FCC received was in June of 1996, asking for the creating of event broadcast stations. These stations would function much like the low-power AM stations used to transmit travel information, but would be used at major events for the time the event is occurring. These stations would

operate with one watt to possibly five watts. The title of this petition is "Amendment of Part 73 of the Rules and Regulation to Establish Event Broadcast Stations," and its number is RM-9246.

The second petition was received in July of 1997 and requests that the FCC create micro-power AM and FM services. These stations would operate at one watt, with a maximum tower height of 50 feet and be vertically polarized. This petition has gotten the largest amount of press, as it was the focus of articles in both *BROADCASTING and CABLE* and *RADIO WORLD*. The title of this petition is "Petition for a Microstation Radio

Broadcasting Service" and it's number is RM-9208.

The third petition is a very detailed request to the FCC that outlines four different low-power FM services. It was received by the FCC on February 20 of 1998.

The first is the current Part 15 FM service that limits radiation to 250 uV/m at 3 meters.

The second service would be a service that would be covered under the current Part 73 rules for broadcast stations and

(continued on page 6)

## CHAPTER 24 OFFICERS

### CHAIR:

**Fred Sperry (Wis. Public TV)**  
W - 264-9806 FAX - 264-9646  
fsperry@ecb.state.wi.us

### VICE-CHAIR:

**Kevin Ruppert (WISC-TV)**  
W - 271-4321  
kruppert@wisctv.com

### SECRETARY:

**Neal McLain (CTI)**  
W - 831-4636  
nmclain@compuserve.com

### TREASURER:

**Stan Scharch (WISC-TV)**  
W - 271-4321  
sscharch@wisctv.com

## COMMITTEE APPOINTEES

### Program Committee:

**Mark Croom** 271-1025  
**Denise Maney** 277-8001  
**Kerry Maki** 833-0047  
**Steve Zimmerman** 274-1234

### Membership and Past-Chair:

**Paul Stoffel**

### Sustaining Membership: Fred Sperry

### Strategic Planning: Dennis Behr

### Special Events: Kevin Ruppert

### Certification and Education:

**Jim Hermanson** 836-8340  
**Tim Trendt (UW-Platteville)**

### Frequency Coordination:

**Tom Smith** W - 263-2174  
smithtc@vilas.uwex.edu

### SBE National Board Member & Chapter Liaison:

**Leonard Charles**  
W - 271-4321 FAX - 271-1709  
lcharles@wisctv.com

## March Business Meeting Minutes

Chapter 24 of the Society of Broadcast Engineers met on Wednesday, March 18, 1998, at J.T. Whitney restaurant in Madison, Wisconsin. There were 24 persons in attendance, including 20 members (all certified) and four guests. The meeting was chaired by Chapter 24 Chair Fred Sperry.

Call to order: 7:29 pm. On unanimous voice vote, the minutes of the February meeting were approved as published in the March Newsletter.

Treasurer's Report (reported by Chapter Treasurer Stan Scharch): the chapter balance stands at \$1,553.69.

Newsletter Editor's Report (reported by Newsletter Editor Mike Norton): The deadline for the April Newsletter is midnight 4/3/98; the folding party is 5:30 pm 4/8/98 at WKOW-TV.

Membership Report (reported by Paul Stoffel): The Chapter membership currently stands at 71 members, of which 39 are certified. The Chapter currently mails 139 Newsletters each month.

Sustaining Membership Report (reported by Fred Sperry): Recent renewals include WMTV, Teleport Minnesota, and maney-logic. The Chapter now has 26 sustaining members.

Program Committee: The April meeting will include elections for the upcoming year, and the annual NAB Convention roundup.

Certification and Education (reported by Jim Hermanson): The deadline for the examinations to take place at the NAB Convention has passed. The next local examinations will take place in June; the application deadline is 4/24/98.

Frequency Coordination Report (reported by Tom Smith): WTMJ-TV, Milwaukee, has coordinated a base station for a news-gathering helicopter.

National Liaison Report (reported by Leonard Charles and Fred Sperry): (1) Membership renewals, still \$55.00 per year, are due April 1. (2) Several SBE-related events will take place at the NAB Convention in Las Vegas; for further information, see the SBE website. (3) SBE plans to file comments in connection with the FCC's consideration of EAS rules applicable to cable television systems. (4) The FCC has issued an NPRM in connection with a proposed low-power FM service. (5) Nominations are now open for national awards; the Chapter is now considering suggestions for nominations.

Old Business: Sperry reiterated the possibility of changing the chapter's legal status to non-profit Wisconsin corporation, noting that SBE national headquarters has recommended that all chapters consider incorporation in their respective states and territories. Sperry noted that the bylaws require the

(continued on next page)

## March Minutes (continued)

approval of the membership for any expenditure exceeding \$300; the cost of incorporation is estimated at \$650.00. On motion by Stan Sarch, second by Leonard Charles, and unanimous voice vote, the membership authorized the officers to spend up to \$700.00 to cover the cost of incorporation.

New Business: (1) Steve Paugh, speaking on behalf of the Nominations Committee, noted that elections of chapter officers will take place at the April meeting. All current officers have agreed to run for another term of office. Nominations are due by April 1, 1998; ballots will be published on April 3, 1998. Anyone interested in running for office, or wishing to nominate another member, should advise Jim Hermanson at 608-836-8340 or [jmh@execpc.com](mailto:jmh@execpc.com). (2) Tom Weeden described a recent interference incident in which the signal of a Dallas DTV Station, WFAA-DT, caused interference to medical monitoring equipment in nearby hospitals. Tom suggested that Chapter 24 set up a task force to study the possibility of similar interference cases when Madison-area stations activate their DTV transmitters.

The business meeting was adjourned at 7:48 pm. The program consisted of a discussion of ATM signal transmission presented by Steve Shepard and Bill Mitsiopoulos of Fore Systems.

Submitted by Neal McLain, Secretary

<b>Jim Pianowski</b>	Tektronix, Inc.
Central Regional Manager	<b>Video and Networking Division</b>
Western Area	515 West Algonquin Road, Ste 100
	Arlington Heights, Illinois 60005
	<a href="mailto:james.j.pianowski@tek.com">james.j.pianowski@tek.com</a>
	800 458-7587 ext. 6797 Voice Mail
	847 431-5755 Mobile
847 734-6797	847 381-4738 Home
847 364-7582 Fax	800 452-1368 Pager

**Tektronix**

	<b>HARRIS CORPORATION</b>
<b>HARRIS</b>	<b>BROADCAST DIVISION</b>
	District Sales Office:
	1913 Fairoak Road
	Naperville, IL 60605
<b>Tom Harle</b>	TEL: 708-420-8899
<b>DISTRICT SALES MANAGER</b>	FAX: 708-420-9171
<b>RADIO</b>	
	e-mail: <a href="mailto:tharle@harris.com">tharle@harris.com</a>
	Sales: 800-622-0022

## AMATEUR RADIO NEWS

By Tom Weeden, WJ9H

- The FCC has suggested several rules changes that could affect Amateur Radio, including replacement of the venerable FCC Form 610. Among the proposed changes: to require applicants and licensees to supply a taxpayer identification number (TIN), and to file electronically. The FCC also plans to consolidate the application procedures for all Wireless Telecommunications Services into a single set of rules.

- Hams in the Gainesville, Georgia, area responded quickly March 20 after a tornado struck northeastern Georgia. The storm left a dozen dead and more than 100 injured. The Lanierland Amateur Radio Club (LARC) and Hall County Amateur Radio Emergency Service (ARES) handled what LARC President Terry Jones, K4FB, called "a massive amount of radio traffic." Jones said the tornado knocked out power, and cellular telephone systems soon became overloaded and unusable. No telephone service was available in the affected area, so the LARC UHF repeater's autopatch was pressed into service to make emergency phone calls until normal telephone service was restored.

- Amateur Radio's advanced satellite system known as "Phase 3D" is angling for "standby" status aboard the European Space Agency's Ariane 503 rocket in late spring or early summer. Although there is no firm date for the launch of the satellite, construction is nearly finished. The Amateur Satellite Corporation (AMSAT) recently released a statement saying, "After successfully recovering from the setbacks caused by the major structural reworks of last summer and fall, the spacecraft is now once again rapidly nearing flight readiness." The satellite will offer transponders on several amateur bands up to 24 GHz.

(Excerpts from April 1998 "QST" and the March 27 "ARRL Letter" from the American Radio Relay League)

**SBE CHAPTER OF THE AIR:** HamNet meets the second Sunday of each month at 0000 GMT on 14.205 MHz. Hal Hostetler WA7BGX is the Control Station.

### CHAPTER 24 HAS NEW HTML NEWSLETTER EDITOR

By Leonard Charles

provided by our editor Mike Norton.

I am happy to announce that Steve Paugh has taken over the HTML version of the Chapter 24 newsletter on our web site. His first issue is the March '98 issue, now available on the web.

We will no longer be posting a text-only version of our newsletter. If you need to have it in text form, you can do a "save as text" from your browser while viewing the web version.

We will continue to have available a PDF version for those of you with the Adobe Acrobat reader. This version is

Congratulations Steve on successfully taking over this monthly project.

	PHONE <b>608-274-1515</b>
<b>WMTV • MADISON</b>	FAX <b>608-271-5193</b>
615 FORWARD DRIVE	
MADISON, WI 53711	
<b>WORKING FOR YOU!</b>	
<a href="http://www.nbc15.com">www.nbc15.com</a> <a href="mailto:feedback@nbc15.com">feedback@nbc15.com</a>	

	<b>Thomas Sibenaller</b> Sales Representative
	<b>Roscor Wisconsin</b>
	2610 Van Loon Road
	La Crosse, WI 54601
	Phone: 608-784-6702
	FAX: 608-785-0505
	e-mail: <a href="mailto:sales@roscor.com">sales@roscor.com</a>

# Broadband Networks Part Twenty (continued)

discuss gain adjustments in more detail later in this article.

- Overspaced amplifiers are placed farther apart than ideal; consequently, the signal level arriving at the input of the downstream amplifier is insufficient. This, in turn, degrades the carrier-to-noise level of the signal. If there's no alternative, it's usually possible to tolerate a 1- or 2-dB degradation in noise performance; however, as a general rule, overspacing should be avoided.

Many factors dictate spacing differences such as those illustrated in Figure 2:

- If branch trunks are required, splitters or directional couplers must be inserted

into the line; these devices introduce additional loss. Note, for example, Spans B and E. Span B contains a 2-way splitter, which adds about 4 dB of loss. Span E contains a DC-8 directional coupler; the insertion loss is about 1.4 dB.

- For obvious reasons, amplifiers should be accessible for service. If possible, they should be located near roadways where they can be reached from service vehicles. Any amplifier installed on a utility pole should be located where a bucket truck can reach it without obstructing roadway traffic.

- Pole owners frequently prohibit the installation of amplifiers on certain poles. Poles already supporting other equipment

- even such common items as transformers, capacitor banks, streetlights, and traffic signals - are sometimes declared off-limits (Figure 3).

So the object of the game becomes this: place each amplifier as far away from the previous one as possible without overspacing it.

## AMPLIFIER GAIN

Trunk amplifiers are fitted with two gain controls:

- A variable gain control, usually adjusted with a screwdriver. The range of this control is very limited, typically not more than a decibel or two.

- A fixed attenuator installed inside the amplifier housing.

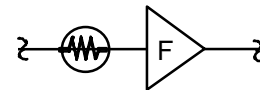

The attenuator is electrically connected ahead of the first active amplification stage to adjust the incoming signal level passed to the first amplification stage. Fixed attenuators are available in 1-dB steps from 0 dB up all the way up to about 25 dB.

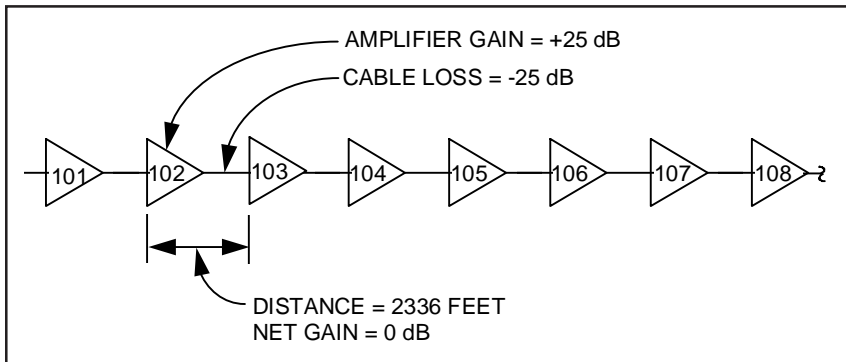

Figure 1. Ideal trunk amplifier cascade. Note that the net gain through one amplifier and the subsequent span of cable is zero decibels, or "unity gain."

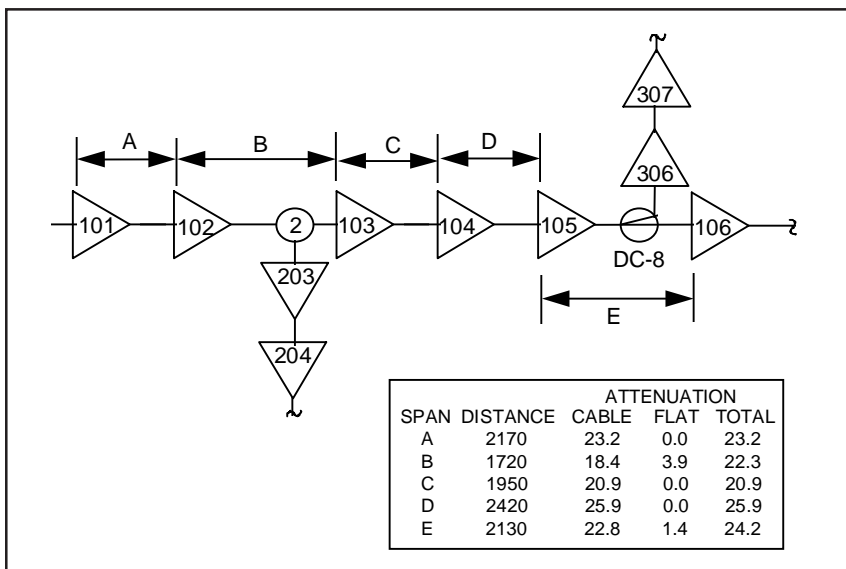

Figure 2. A real-world (albeit hypothetical) trunk amplifier cascade. Note that the actual loss between amplifiers almost never equals the gain of the amplifier; hence, the gain of each amplifier must be adjusted to compensate.

This fixed-attenuator arrangement is necessary to protect the first amplification stage from being overdriven. As we noted in an earlier article (October 1996), the noise performance a trunk amplifier is determined by the "noise figure" of the amplifier. The noise figure is set by the first amplification stage; accordingly, the transistors used in that stage are optimized for best noise figure. But they are not designed to operate at a higher level - that's the job of the output stage. While a higher input level would - theoretically - improve noise performance, it would degrade distortion performance.

By proper selection of the fixed attenuator, in combination with proper adjustment of the variable gain control, a technician can set each amplifier for optimum performance at any input level - provided, of course, that the amplifier is

(continued on next page)

## Broadband Networks Part Twenty (continued)



**Figure 3.** A CATV trunk amplifier on a joint utility pole. The amplifier is the strand-mounted device just to the left of the pole. This particular pole is located on a side street so that a bucket truck parked near the pole doesn't block traffic.

not overspaced.

### EQUALIZATION

In our discussion of coaxial cable in June 1996, we noted that the attenuation of coaxial cable varies as a function of frequency: the higher the frequency, the higher the attenuation. Assuming that the broadband signal leaving one amplifier is "flat" (all signals are at approximately the same level), it's "tilted" when it arrives at the input to the next amplifier. The degree of tilt depends on the amount of cable in the span; if it's all cable (no splitters or directional couplers), the low-end attenuation may be less

than half the high end attenuation.

To take a specific case, let's assume a cascade of amplifiers operating at the following signal levels:

Input: +6 dBmV  
 Output: +31 dBmV  
 Gain: 25 dB

These are the same levels we derived in our discussion of amplifier cascades in November 1996. These levels are, of course, applicable only to the highest frequency carried on the network. If we again assume that the highest frequency is 402 MHz, then the attenuation at the lowest frequency (54 MHz) is only about 8 dB.

Obviously, we can't present this signal to the amplifier without removing the tilt. If we did, the excessive signal at the low end would surely overdrive that first amplification stage.

To solve this problem, we insert another device into the amplifier housing ahead of the first amplification stage: an equalizer:

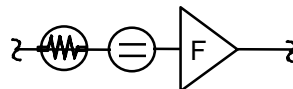

Equalizers are available in a variety of values capable of compensating for cable attenuation ranging from zero to 25 dB.

### THERMAL COMPENSATION

To further complicate things, the attenuation of coaxial cable isn't constant. It varies with temperature: the warmer the cable, the higher the attenuation. Attenuation can vary as much as 10% from a cold winter night to a hot summer day.

So amplifier designers have to

incorporate some means of compensating for level variations caused by temperature changes. The simplest device is called a "thermal equalizer"; it's simply a thermally-controlled gain control installed inside the amplifier housing:

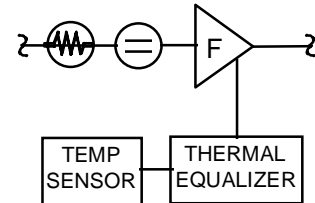

Unfortunately, thermal equalizers don't work very well. Cable installed underground remains at a more constant temperature than aerial cable, so a thermal equalizer actually makes things worse. Moreover, the temperature of the amplifier itself (and hence, the equalizer) isn't consistent: an amplifier in direct sunlight gets warmer than an amplifier under a tree.

### AGC/ASC

The best way to solve the problem of varying levels is to incorporate an automatic circuit which directly controls the output level of the amplifier to keep it within specified limits. This circuit is typically called "Automatic Gain Control/Automatic Slope Control" or AGC/ASC. It automatically controls two amplifier parameters:

- Gain, to compensate for changes in level due to temperature changes. Gain is adjusted by monitoring the high end of the broadband spectrum - the frequencies that are most sensitive to temperature change.

- Slope, to compensate for changes in tilt. Slope is adjusted by monitoring the low end of the broadband spectrum and adjusting it to the same level as the

(continued on page 6)

**TELEPORT MINNESOTA**  
 Mark Durenberger  
 General Manager  
 90 South 11th Street  
 Minneapolis, MN 55403  
 Office (612) 330-2433  
 Fax (612) 330-2603  
 e-mail durenberger@teleportmn.com

**GROUP NETWORK SERVICES**

**CLARK WIRE & CABLE**

1355 ARMOUR BOULEVARD  
 MUNDELEIN, IL 60060-4401  
 (800) CABLE-IT · (847) 949-9944  
 FAX: (847) 949-9595  
 E-MAIL: SALES@CLARKWC.COM  
 WWW.CLARKWC.COM

**27 abc**  
**WKOW Madison**

5727 Tokay Boulevard  
 Madison, Wisconsin 53719  
 (608) 274-1234  
 Fax: (608) 274-9514

# Broadband Networks Part Twenty (conclusion)

high end.

The AGC/ASC circuit monitors the output of the amplifier by sampling the output signal:

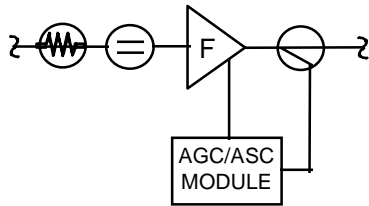

It then compares the sampled signal with an internally generated standard signal and adjusts the amplifier parameters accordingly.

### PUTTING IT ALL TOGETHER

Figure 4 is a block diagram of a typical modern two-way trunk-bridger amplifier, in this case a 550-MHz Network Amplifier manufactured by Philips Broadband Networks, Inc. Note that this amplifier incorporates many of the features we have discussed: an equalizer for the forward amplifier, two attenuators (one for the forward amplifier and one for the return amplifier), and AGC/ASC gain and slope control.

Every amplifier manufacturer in the business makes an amplifier similar to this one. This amplifier is the workhorse of the cable television industry, and it promises to play a similar role in the broadband networks of the future.

This series of articles will continue in June with a discussion of outside plant: what a broadband network actually looks like in the field.

*Special thanks to Greg Davis of Philips Broadband Networks, Inc. for providing the amplifier block diagram reproduced in Figure 4.*

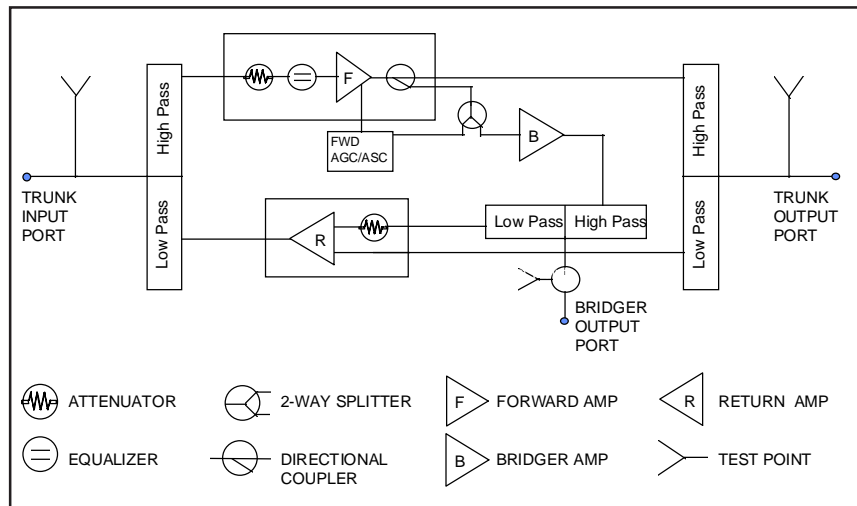

**Figure 4.** Block diagram of 550-MHz Network Amplifier manufactured by Philips Broadband Networks, Inc. Power circuitry has been omitted for clarity. Drawing provided courtesy of, and reprinted with the permission of, Philips Broadband Networks, Inc.

## Low Power FM (continued)

would be operate at power levels of 50 watts to 3 kilowatts at 100 meters. The top power is the same as the old class A FMs. They would be treated the same as existing stations and would be a primary service station, not being able to be bumped off the air by a new full-power station.

The third service proposed is Secondary Service Station that would operate under Part 74 of the rules like low-power TV. These stations could be bumped off the air by new full-power stations. They would operate with one to fifty watts at up to 150 feet.

The fourth service proposed is a Special Event Station that would operate with up to 20 watts at no higher than 100 feet. These station would be licensed to operate for a period of 10 days or less. This petition outlines allocation issues in detail, along with ownership restrictions. The title of this petition is

“Proposal for Creation of the Low Power FM (LPFM) Broadcast Service.”

All of these petitions noted the effects of consolidation on the broadcast industry, along with the lack of diversity of ownership, loss of diverse and local voices, rise of pirate radio, and limited ownership opportunities for small business persons.

In articles in both *RADIO WORLD* and *BROADCASTING and CABLE*, these issues were also discussed, with the NAB and station owners coming out against the proposal. FCC Chairman William Kennard also expressed concern over the consolidation and diversity issues and indicated he was open to the proposals.

Comments are due on April 27, 1998 and replies are due May 26, 1998.

From the FCC MASS MEDIA WEB SITE ([www.fcc.gov](http://www.fcc.gov)), *RADIO WORLD* and *BROADCASTING and CABLE*

**SONY** Kevin Peckham  
Account Manager  
Broadcast Products Division

Sony Communications Products Company  
1200 North Arlington Heights Road  
Itasca, Illinois 60143  
Telephone (608) 271-3778  
(708) 773-6046

Service Center (708) 773-6037  
Emer. Tech. Assist. (201) 833-9533  
National Parts Center (800) 538-7550

**FOX 47**  
WMSN MADISON  
A SULLIVAN BROADCASTING STATION

7847 BIG SKY DRIVE  
MADISON, WISCONSIN 53719  
(608)833-0047 • FAX(608)833-5055

**BCS** Wireless  
Tower Construction  
Maintenance  
HDTV upgrades

John W. Crooks (608) 527-5670  
Vice President

Over 40 years of service to the Broadcasters.

## Emergency Alert System Update

*By Leonard Charles,  
National EAS Committee Chair*

What follows is a condensed version of the EAS Committee report delivered to the SBE Board of Directors at their Spring meeting at NAB.

### Petition Progress

As reported at the Fall SBE Board meeting in Syracuse, the EAS Committee filed its FCC Petition for EAS rules change in September of '97. Since then, comments on it were received from the NAB and from MTS, an EAS equipment manufacturer. The SBE has responded to those commentaries. We are still waiting for a Notice of Proposed Rule Making (NPRM) generated from this Petition. The FCC had stated in January that the SBE petition and one presented by the NWS will most likely be rolled into one NPRM sometime after the Further NPRM on the Cable industry EAS integration is complete.

### NAC Participation

The SBE EAS Committee was well represented at the January 1998 National Advisory Committee (NAC) meeting in Washington DC. Committee Chair Leonard Charles was invited to deliver a short presentation on SBE efforts concerning implementation of EAS by its members. Charles also expressed concerns about on going problems in the deployment of EAS and the lack of regulatory urgency with which these problems are treated.

Also at this meeting were two other SBE EAS Committee members, Richard Rudman representing the State of California Emergency Committee and Gary Timm representing the State of Wisconsin Emergency Committee.

The morning portion of the meeting included presentations by all of the SECC Chairs and by all of the industry representatives present. Perhaps the most heated debate ensued over the way Cable will do EAS as mandated in the Second EAS Report and Order (R&O). The SBE and NAB representatives spoke of what they saw as the negative way Cable EAS participation will impact the public if carried out as mandated in that

second R&O. The two organizations agreed that it will be an EAS public relations disaster. This will result from the forced override of all cable channels during EAS alerts or tests.

The discussion resulted in an approved motion by the NAC to urge the FCC to delay cable EAS implementation until this override issue can be fully studied. Surprisingly enough, the only cable industry representative present at the meeting did not want any further delays, saying his industry is already purchasing equipment.

The afternoon was a discussion of problems and how to deal with them. Also included in the afternoon session was a discussion of some of the points of the SBE petition. There seemed to be support on most issues except the move from a Required Monthly Test to a Quarterly Test. Most SECC Chairs said they are not ready for that yet, but might consider it after a long string of successful Monthly Tests in their states. On the other points of the SBE Petition the NAC was; in support of extending the RMT relay window; they were near unanimous in opinion that the PEP network is not adequate to cover the country for a national emergency; they split on elimination of the old EBS alert tone in an EAS message; and they split on including a text protocol in the EAS rules and the resulting text capability in EAS equipment. Motions to express their support to the FCC carried, on the issues that there was a majority agreement.

### NWS EAS Filing

During the NAC meeting it was revealed that the NWS has had at the FCC for quite some time a document proposing how the coding should be modified in the NWS SAME system and thereby they urged the same changes be made in the EAS rules. Shortly after the NAC meeting, that document was released by the FCC for comment as an official Petition. The SBE EAS Committee found it necessary to submit comments on this Petition. Though the SBE comments were mostly favorable, there is an area of the document that appeared counter productive to the progression of EAS.

The NWS proposes changing not only some event codes to encompass more non-weather related emergencies, but also proposes to change the location coding to include non alpha characters which would then be used to represent specific sites and areas through regional specific coding schemes. These specific schemes would be used to convert the codes to electronic text to spell out a more exact description of the site and the emergency necessitating the alert. The Committee has a huge problem with this.

First of all, because these code schemes would vary by region, there is only a slim chance that they would be written into the rules. As such, some manufacturers, who have told SBE time and time again that they will not put anything into their equipment that is not spelled out in the rules, will not add these codes to their software. What will result is that only those owners of specific manufacturer's EAS units that will allow regional codes in their equipment will have access to the text that this specific coding will produce. The Committee deems this situation not acceptable.

The SBE position is that the text protocol proposed by the SBE EAS Committee in its EAS Petition is a much more viable way to get regional specific text into and out of the system. Our proposal would implement the text protocol in all EAS equipment. The actual text is generated and decoded outside of the equipment loop and simply uses the equipment as a means of transport from source to destination. As such, once our protocol is implemented, a region can put any text it wants through the system without any need for it to be specified in the rules. It's the only way that all SBE members will have access to this emergency electronic text, no matter which equipment they own.

Further, the NWS proposes that this extra coding be carried in a broadcasters main audio channel but advocates that the baud rate be increased during the special text code portion of the transmission and decreased again after it in order to shorten the audible digital audio. Such a method would likely involve a hardware change in the EAS equipment. The SBE EAS Committee has been very

(continued on page 9)



## FCC Rulemakings

Compiled by Tom Smith

### PROPOSED

**FCC 98-40; MD Docket No. 98-36  
Assessment and Collection of  
Regulatory Fees for Fiscal Year  
1998**

The FCC is conducting its yearly rulemaking to determine the fees it charges users of the spectrum for the FCC's regulatory activities. Comments are due on April 22, 1998 and replies are due on May 4, 1998. This notice was adopted on March 13, 1998 and released on March 25, 1998. Published in the FEDERAL REGISTER on April 2, 1998 on pages 16,188-16,215. Note: The proposed fees are listed on page 22 of the March 30th issue of BROADCASTING and CABLE.

**MM Docket 97-182; DA No. 98-458  
Preemption of State and Local  
Zoning and Land Use Restrictions  
on the Siting, Placement and  
Construction of Broadcast  
Transmission Facilities**

The FCC is asking for comments concerning the preparation of an Environmental Impact Statement in connection to the proposed rulemaking on the preemption of local zoning rules for broadcast tower construction. This notice is in response to a petition from the National Autubon Society.

Comments are due on April 14, 1998 and replies are due on April 29, 1998. This notice was published in the FEDERAL REGISTER on March 20, 1988 on pages 13610-13612.

**MM Docket No. 98-35  
1998 Biennial Regulatory Review -  
Review of the Commission's  
Broadcast Ownership Rules and  
Other Rules Adopted Pursuant to  
Section 202 of the  
Telecommunications Act of 1996**

The FCC is required by Congress to review the ownership rules every two years. Subjects that the FCC is seeking information on outstanding proceedings

that include the TV duopoly rules, the one to a market rule that prohibits common ownership of radio and TV stations in the same market, daily newspaper and radio ownership in the same community.

The FCC will also look at the previous ownership rule changes concerning the National TV Ownership Rule, the Local Radio Ownership Rules, the Dual Network Rule, Cable/Television Crossownership rule, Ownership Waivers, Experimental Stations and the UHF TV Discount Rule. They are asking for information on the impact of these rules, and possibly changes in the rules.

All of the Commissioners issued separate statements on the notice and the statements provide some insight on each of their views on ownership limits.

Comments are due on May 22, 1998 and replies are due on June 22, 1998.

### FINAL RULES

**CS Docket No. 97-55, CS Docket 97-321, ET Docket 97-206**

**Commission Finds Industry Video  
Rating System Acceptable; Adopts  
Technical Requirements To Enable  
Blocking of Video Programming  
(The "V-CHIP")**

This notice fulfills the requirement of Section 551 of the Telecommunications Act of 1996 that the FCC determine if the video programming industry has established acceptable voluntary rules for rating programs for sex, violence or indecent material. The FCC has found the ratings system acceptable.

The Second part of this notice sets the technical standards for the V-CHIP and the timetable for manufacturers to start installing them. Half the sets sold that are 13 inches and over will have them installed by July 1, 1999 with all sets needing to have them by January 1, 2000.

This notice was adopted on March 12, 1998.

**MM Docket No. 87-268; FCC 98-24  
Advanced Television Systems and  
their impact on the Existing  
Television Service**

This notice finalizes the allocation table for the new digital TV stations and sets the technical standards for separation and power limits for DTV stations. In the full rulemaking there is discussion of all the petitions and decisions concerning the DTV allocation table. The full notice is several hundred pages long. The notice in the FEDERAL REGISTER is under 20 pages.

This notice was adopted on February 17, 1998, released on February 23, 1998, and becomes effective on April 20, 1998. It was published in the FEDERAL REGISTER on March 20, 1998 on pages 13,546-13,563.

**MM Docket No. 87-268; FCC 98-23  
Advanced Television Systems**

This notice reaffirms and clarifies some of the FCC rules concerning the transition to DTV. Issues discussed include spectrum fees, minimum hours, public interest obligations, simulcast, financial qualifications, transition timetable, satellite stations, must carry, effects on radio stations, and non-commercial station issues.

This notice was issued on February 17, 1998 and released on February 23, 1998. It becomes effective on May 1, 1998 and was published in the FEDERAL REGISTER on April 1, 1998 on pages 15,775-15,784.

From FCC WEB SITE ([www.fcc.gov](http://www.fcc.gov))  
and the FEDERAL REGISTER  
([www.access.gpo.gov](http://www.access.gpo.gov))

The Chapter 24 Newsletter is published monthly. Submissions of interest to the broadcast technical community are always welcome. You can email your articles to:

MNorton@ecb.state.wi.us

or send them to:

SBE Chapter 24 Newsletter  
Editor  
5174 Anton Dr. #15  
Madison, WI 53719-4201

## SBE Short Circuits - March 1998

By John Poray, CAE  
Executive Director

### NOMINEES FOR SBE NATIONAL AWARDS SOUGHT

It's time to nominate someone (even yourself!) or your chapter for one of the SBE National Awards presented each year. Nomination Forms are in the February/March issue of the SBE SIGNAL or can be obtained by contacting the SBE National office at (317) 253-1640. Presentation of the Awards will be made during the SBE Awards Dinner at the SBE National Meeting in Bellevue, Washington, October 28. Deadline for nominations is June 1.

### SBE GUIDE TO WRITING BROADCAST STATION OPERATIONS MANUALS RELEASED:

SBE has released another publication that many broadcast engineers and managers will find useful. The "SBE Guide To Writing Broadcast Stations Operations Manuals," is written by Fred Baumgartner, CPBE. Fred is a past national board member of SBE and has served as Chief Engineer at KDVR-TV Denver and WTTV-TV Indianapolis. He has also been chief at WIBA radio in Madison, Wisconsin and KHOW radio in Denver. Fred is now with TCI at the National Digital Television Center in Colorado.

The "Guide" is a comprehensive collection of operator's manuals, technical guides, employee handbooks, job descriptions, evaluations, contracts and sample letters. It provides a great basis to write your own station operations manual. To save you even more time and money, the book comes with many of the sample forms, contracts and guidelines on a 3.5" disc

so you may easily modify them to your own specific needs.

The price for the "Guide," including the disc, is \$69 for SBE members. Non-member price is \$89. All orders must include \$2.00 shipping per book. Orders from Indiana addresses must add 5% sales tax.

## LESS THAN EXPECTED AUCTION RETURN

By Tom Smith

The FCC closed another auction on March 25, 1998 with less than the anticipated outcome. The FCC received \$578,663,029 for the auctioning of the Local Multipoint Distribution Service (LMDS). This service operates at 28 GHz and will provide video, telephone, data and internet access. Two blocks of spectrum were auctioned in 493 Basic Trading Areas. One block was 1,150 MHz and the other block was 150 MHz.

This auction was started on February 18<sup>th</sup> after a number of delays. It was to occur in the fall of 1997, but many potential bidders had difficulty in obtaining financing. The phone companies were not allowed to bid for the 1,150 MHz blocks, so they sat out of the auction. It was expected that the FCC would raise \$13 per pop (per person in each trading area) or \$4.1 billion, and was only to raise an average of \$1.85 per pop. This auction follows the auction for the Wireless Communication Service last fall that also failed to meet expectations and impacted on the planning for the LMDS auctions.

From FCC Press Release and INTER@CTIVE WEEK

To order, call the SBE National Office at (317) 253-1640. You may fax your request to SBE at (317) 253-0418. Payment by credit card or check must accompany orders. Send mail orders to: Operations Manuals, Society of Broadcast Engineers, 8445 Keystone Crossing, Suite 140, Indianapolis, IN 46240.

## EAS Update (continued)

careful not to propose any changes that cannot be implemented by software only. The committee also urges that text never be transmitted in broadcasters main audio channels but only in background channels from emergency sources to the broadcaster. Therefore the SBE cannot agree with this part of the NWS Petition.

### FCC Second Further Notice of Proposed Rulemaking

In March of 1998 the FCC finally released its Further Second NPRM on the Cable industry EAS participation as it involves the selective override of a broadcaster's cable channel. The comment period is open until April 20<sup>th</sup>. The EAS Committee has written and has forwarded comments on this NPRM to the SBE FCC Liaison Committee Chair Dane Ericksen. In these comments, the committee urges the FCC to take a radically different method of cable EAS participation. If these comments clear this committee and receive full Board approval, they will be published on the web site.

### Additions to the Web Site

The EAS Committee section of the SBE web site now contains the FCC Second Notice of Further Proposed Rulemaking. It also has a section which contains all the Comment and Reply Comment filings on EAS that the SBE EAS Committee is aware of.

### Chapter 24 World Wide Web Site

<http://www.sbe24.org>



Steve Paugh is the editor for the HTML Version of this Newsletter, available monthly on the SBE Chapter 24 web page.



Becky Hilborn  
Broadcast Sales  
Specialist

40W267 Keslinger Road  
LaFox, IL 60147 USA

Phone: (800) 348-5580  
(630) 208-2372  
FAX: (630) 208-2450  
email: becky@rell.com  
WWW: <http://www.rell.com>

Your Tube and  
Broadcast Component  
Source.



# TELECOM INDUSTRY NEWS

By Neal McLain

## FCC'S TROY DECISION RESTRICTS EFFORTS BY MUNICIPALITIES TO REGULATE TELECOMMUNICATIONS CARRIERS

The FCC has issued a "declaratory ruling" resolving a dispute between TCI and the City of Troy, Michigan. This decision restricts efforts by Troy - and, by implication, other municipal governments as well - to "franchise" or otherwise regulate competitive telecommunications carriers. Although the FCC decided the case on narrow technical grounds, it took the opportunity to express broad concerns about attempts by a number of local governments to impose local regulations on telecommunications carriers.

### THE MEANING OF "MANAGEMENT"

This case hinges on a provision of the Telecommunications Act 1996 which allows municipalities to "manage" their rights-of-way (i.e., the city streets) and to require "fair and reasonable compensation" for the use of these rights-of-way. But the act does not specify what kinds of requirements are permissible under this provision.

Even in the absence of formal definitions, some municipal requirements are generally acknowledged to fall within the meaning of "managing" rights-of-way. Some examples:

- Regulations which affect the flow of vehicular traffic.
- Regulations concerning the location and depth of buried cables and conduits.
- Requirements that the work area be "restored" to its previous condition: disturbed pavement and plantings must

be replaced; damage must be repaired; the work area must be clean; etc.

- Compensation directly related on the actual cost of regulation, such as a fee-per-inspection, a fee based on a percentage of a construction contract (similar to a building permit fee), or an annual per-foot-of-cable fee.

But a number municipal governments, including Troy, have attempted to extend their management authority to include such matters as rate regulation, fees based on revenue, interconnection requirements, and restrictions on the kind of traffic which can be carried. These attempts were at the root of the FCC action.

### FACTS OF THE CASE

The case at hand involved a dispute between TCI Cablevision of Oakland County, Inc. and the City of Troy, Michigan. Under Troy's Telecommunications Ordinance, all telecommunications carriers except Ameritech are required to obtain a "telecommunications franchise" in order to provide telephone service within the city. Ameritech was exempted on the grounds that it already served the city before the ordinance was passed.

TCI already held a cable television franchise in Troy. A few years ago, TCI began to upgrade its cable television distribution network; as part of this project, it wished to install several fiber optic links. TCI did not intend to provide telephone service; accordingly, it did not apply for a telecommunications franchise.

The City refused to grant permits for the construction of the fiber links on the grounds that the fiber links could be used to provide telephone service. According to the city, even though TCI did not intend to provide telephone service, the mere fact

that it was building a network which was technically capable of providing telephone service triggered the requirement that it obtain a telecommunications franchise.

TCI petitioned the FCC, claiming that the city's telecommunications-franchise ordinance was an unreasonable extension of the city's power to manage its right of way, and was, therefore, in violation of the Telecommunications Act.

### THE FCC RULING

The FCC ruled on narrow grounds. It preempted the City's requirement that TCI needed a telecommunications franchise, and ordered the city to grant the fiber permits. on the grounds that TCI did not intend to provide telephone service. In its Report and Order, the Commission stated, "In practice and in effect, the City's refusal amounts to nothing less than a denial of TCI's permit applications on grounds forbidden under the 1996 [Telecommunications] Act."

But it did not rule on the validity of the City's telecommunications-franchise ordinance itself.

Nonetheless, it took the opportunity to express its opinion about the attempt by municipalities generally, including Troy, to regulate competitive telecommunications carriers. Again quoting from the Report and Order:

"Our concern is that some localities appear to be reaching beyond traditional rights-of-way matters and seeking to impose a redundant "third tier" of telecommunications regulation which aspires to govern the relationships among telecommunications providers, or the rates, terms and conditions under which telecommunication service is offered to

(continued on next page)



**VIDEO IMAGES**

Milwaukee  
Madison  
Chicago  
Indianapolis

**Bob Marek**  
Account Executive

Video Images, Inc.  
2137 S. Stoughton Road • Madison, WI 53716  
Phone: (608) 221-8888 • FAX: (608) 221-9252  
Internet: <http://www.videoimages.com/>



**LOUTH**  
A U T O M A T I O N

**Kurt Schini**  
Central Regional Sales Manager

7402 Timberlake Trail, Suite 204, Madison, WI 53719  
(608) 277-0702 FAX (608) 277-0706  
e-mail 105224.2131@compuserve.com



**JAMES F. DOHERTY**  
Traffic Supervisor  
Satellite & Video Services

**Norlight™**  
TELECOMMUNICATIONS

275 NORTH CORPORATE DRIVE  
BROOKFIELD, WI 53045-5818  
414.792.7708 FAX: 414.792.7717  
e-mail: [jfd@norlight.com](mailto:jfd@norlight.com)

## Telecom Industry News (continued)

the public. For example, the Troy Telecommunications Ordinance contains provisions that, among other things, require franchisees to interconnect with other telecommunications systems in the City for the purpose of facilitating universal service, provide for regulation of the fees charged for interconnection, and mandate "most favored nation" treatment for the City under which a franchisee providing a "new service, facility, equipment, fee or grant to any other community ... within the State of Michigan" shall provide the same to the City of Troy.

"Such Ordinance provisions will be difficult to justify under section 253(c) [of the Communications Act of 1934 as amended by the Telecommunications Act of 1996] on the grounds that they are within the scope of permissible local rights-of-way management authority or other traditional municipal concerns such as police, fire, building code enforcement or other public safety concerns. In addition, several of these provisions seem redundant of comprehensive federal and state regulatory programs governing inter-carrier interconnection and universal service obligations and support. Given the likelihood of such local requirements impeding competition and imposing unnecessary delays on new entrants, attempts to impose a redundant "third tier" of regulation at the local level will be met with close scrutiny by the Commission."

The Commission also expressed concern about the "discriminatory application" of the ordinance in that it exempts Ameritech:

"An especially troubling issue alluded to in the record concerns the discriminatory application of telecommunications regulation, whether at the state or local level. ... One clear message from section 253 is that when a local government chooses to exercise

its authority to manage the public rights-of-way or to require fair and reasonable compensation from telecommunications providers, it must do so on a competitively neutral and nondiscriminatory basis. Local requirements imposed only on the operations of new entrants and not on existing operations of incumbents are quite likely to be neither competitively neutral nor nondiscriminatory."

The Troy Telecommunications Ordinance is still on the books. But by using words such as "will be met with close scrutiny," the Commission is clearly signaling a warning that local municipalities cannot impose unreasonable barriers to competition in the telecommunications marketplace.

Source: MEMORANDUM OPINION AND ORDER. TCI CABLEVISION OF OAKLAND COUNTY, INC. Petition for Declaratory Ruling, Preemption and Other Relief Pursuant to 47 U.S.C. 541, 544(e), and 253.

### Employment Opportunity

#### Audio/Visual Technician

Are you an electronically savvy electrician with an interest in Audio and Video Systems, Computers, and Telecommunications? Video Images sells and services solutions in Presentation, Distant Learning and Video Conferencing applications and our growth presents an opportunity for you to learn and grow in these rapidly expanding markets.

Send resume to: Video Images, 2137 S Stoughton Rd, Madison, WI 53716, Attn: Julie Wegner

Equal Opportunity/Affirmative Action Employer

David Thorndsgaard  
Broadcast Sales Engineer  
thor@alphavideo.com  
Pager #(800) 236-0034  
Pin 12462  
(800) 388-0008  
7711 Computer Avenue  
Edina, MN 55435  
(612) 896-9898  
FAX (612) 896-9899



James (Jim) B. Rogers  
Western Regional Sales Manager  
(619) 748-2151  
Fax: (619) 748-1879  
Pager: (800) 970-3239  
E-mail: jrogers@comarkcom.com  
JBRCOM@worldnet.att.net



**COMARK**  
a THOMCAST Company  
12612 Arabian Way • Poway, CA 92064 U.S.A.  
http://www.comarkcom.com

## CHAPTER 24 SUSTAINING MEMBERS

### RECENT RENEWALS:

WMTV-TV 15

### THANKS TO ALL OUR SUSTAINING MEMBERS:

- Alpha Video
- BCS Wireless
- CTI
- Clark Wire and Cable
- Comark Communications
- Fuji Film
- Harris Corporation
- Hewlett-Packard
- Louth Automation
- maney-logic
- Niall Enterprises
- Norlight Telecommunications
- Panasonic Broadcast
- Richardson Electronics
- Roscor Wisconsin
- Sarch Electronics
- Skyline Communications
- Sony Broadcast
- Tektronix
- Teleport Minnesota
- Video Images
- WISC-TV 3
- WKOW-TV 27
- WMSN-TV 47



1965 West Ridge Rd.  
P.O. Box 51  
Cottage Grove, WI 53527  
608 / 839-4075  
FAX: 608 / 839-4985

COMMUNICATIONS, LTD. • MADISON, WI  
ANTENNA SPECIALISTS • TOWER Erectors

RICHARD H. WOOD  
President

TOWERS • ANTENNAS  
CONSTRUCTION • MAINTENANCE

RS-422 Remote Control

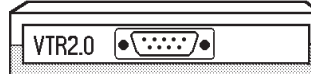

VTR2.0

REW FFWD STOP STBY REC PLAY

Terminal Block for switches and lamps



maney-logic 277-8001



Society of Broadcast Engineers, Inc. 8445 Keystone Crossing Suite 140 Indianapolis, IN 46240



Office (317) 253-1640 Fax (317) 253-0418 Job Line (317) 253-0474 http://www.sbe.org



MAGNETIC MARKETS DIVISION PROFESSIONAL PRODUCTS GROUP

Jerry Van Vliet Account Representative

FUJI PHOTO FILM U.S.A., INC. 1285 Hamilton Parkway Itasca, IL 60143 630-773-7200 Ext. 7293 • 800-877-0555 Ext. 7293 Fax 630-773-6266 • Fuji Voice Mail 800-736-3600 Ext. 7293



Jon S. Gedymin

Video Sales Manager Midwest Region

Hewlett-Packard Company 250 North Patrick Boulevard, Suite 100 Brookfield, Wisconsin 53045-9945

800/477-6111 Ext. 2263 Fax 414/569-0966

Internet jon\_gedymin@hp.com



http://www.CTIinfo.com email - cti@CTIinfo.com Phone - 608-831-4636 Fax - 608-836-1840

VCR Controllers Character Generators Satellite Antenna Controllers Broadcast / Cable Television Consulting

SCHARCH ELECTRONICS CO.

Small Business Communications 1105 Middleton Street MADISON, WI 53717-1078 (608) 831-2266 (800) 831-2266



NIALL ENTERPRISES

P.O. Box 314 Belmont, Wisconsin 53510 (608) 762-5327

John O'Neill

Panasonic

Broadcast & Television Systems Company



Atlanta 1996

HERB VAN DRIEL Direct Sales Manager Entertainment Systems Division

The Official Broadcast Equipment of the 1996 Olympic Games.

1707 N Randall Road Elgin, IL 61023 WI Tel: 608.355.0662 WI FAX: 608.355.0663 HQ Tel: 847.468.5160 HQ Fax: 847.468.5161

Division of Matsushita Electric Corporation of America

SBE

SBE Chapter 24 Newsletter 5174 Anton Drive #15 Madison, WI 53719-4201

FIRST CLASS MAIL

Newsletter edited on Pagemaker 5.0 by: Mike Norton

Contributors this month: Leonard Charles, Neal McLain, Tom Smith, and Tom Weeden. Thanks to Chris Cain for his work on the Chapter 24 WWW page.

© 1998 by SBE Chapter 24. Views expressed herein do not necessarily reflect the official positions of the Society, its officers, or its members. SBE Chapter 24 regrets, but is not liable for, any omissions or errors. The Chapter 24 Newsletter is published twelve times per year. Other SBE Chapters are permitted to use excerpts if attributed to the original author, sources, and SBE Chapter 24.

# APRIL MEETING and PROGRAM



**Society of Broadcast Engineers  
CHAPTER 24 MADISON, WISCONSIN  
Thursday, April 16, 1998**

## **Elections and NAB Review**

**This month's meeting will feature the Annual Chapter 24 Elections for the upcoming year's officers. Also, individuals who attended the NAB `98 show will be invited to share insights into new products and industry trends seen in Las Vegas.**

**Pizza will be provided for members and guests, and maney-logic will provide soda.**

**Dinner at 6:00pm  
Wisconsin Public Broadcasting Center  
3319 W. Beltline Hwy.**

**Meeting and Program follow at 7:00pm**

**Visitors and guests are welcome at all our SBE meetings!**

### **1998 UPCOMING MEETING/PROGRAM DATES:**

<b>Day</b>	<b>Date</b>	<b>Program</b>
Tuesday	May 5	Telephone Company Tour
Wednesday	June 17	Sullivan NOAA Weather Office Tour

Program Committee:	Kerry Maki 833-0047	Denise Maney 277-8001	Steve Zimmerman 274-1234	Mark Croom 271-1025
--------------------	------------------------	--------------------------	-----------------------------	------------------------