



BROADBAND NETWORKS PART 28 - HEADENDS II

By Neal McLain

This is Part 28 in a series of articles about broadband networks. In this article, we'll continue with our discussion of headends.

INTRODUCTION

Last month, we began a discussion of the equipment located in a typical cable television headend. We noted that a typical headend is a "star" network in which a number of NTSC signals are combined into a single wire:

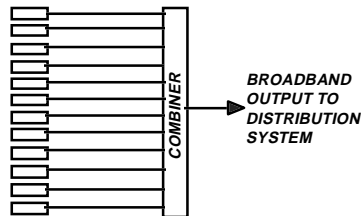

We further noted that three types of devices are commonly used to generate these NTSC signals: strip amplifiers, processors, and modulators.

This month, we'll take a look at how these devices are used in a hypothetical headend, and the kinds of equipment located upstream from these devices.

The design of any headend begins with the channel lineup: a list of the signals to be carried. For the purpose of this discussion, we will adopt the hypothetical 12-channel lineup shown in Figure 1. This lineup doesn't actually exist at any real headend; it was chosen for this article because it's a relatively

(continued on page 4)

Next Meeting:

Tuesday,
February 23, 1999

Year 2000 Station
Preparations

Dutch Treat Dinner
and Meeting

J.T. Whitney's
674 S. Whitney Way
at 5:30pm

Program at
WNWC-AM/FM
5606 Medical Circle
at 7:00pm

In This Issue:

Minutes	page 2
Amateur Radio News	page 3
Local Legals	page 7
Telecom News	page 8
FCC Rulemakings	page 10

Digital Television Demonstration This April At UW Engineering EXPO

By Steve Paugh

Every two years, the University of Wisconsin College of Engineering-Madison sponsors an open house to showcase the UW Engineering Campus, and to present to the public technology exhibits that span all engineering disciplines.

This open house is called the Engineering EXPO, and attracts over 20,000 people. The next EXPO will be in April of 1999. The dates are Friday-April 16, Saturday-April 17 and Sunday-April 18. Unfortunately, this coincides with the opening weekend of the NAB

convention being held in Las Vegas. The EXPO is open to the general public. Friday is usually the day that most of the area schools bring their students in. Saturday is the busiest day and draws the general public. Sunday is more relaxed, but still well attended. Tentative hours of operation are 9 AM-6 PM on Friday and Saturday, and 9 AM to 1 PM on Sunday.

The EXPO has a mixture of UW research displays, UW student exhibits and Commercial exhibits. The UW students are judged on their exhibits on the first day of the event. The event covers the entire Engineering campus,

and the public walks from building to building to view the various exhibits.

Craig Bluschke, A-V facilities Director of the College of Engineering, in cooperation with SBE Chapter 24, is organizing a Digital TV demonstration during EXPO. The college has an auditorium (Room 1610) in the main engineering building that is set up for large screen video projection. He is looking for support from the broadcast community to help put together a high-definition video presentation.

The intent of this demonstration will
(continued on page 3)

CHAPTER 24 OFFICERS

CHAIR:

Fred Sperry (Wis. Public TV)
W - 264-9806 FAX - 264-9646
fsperry@ecb.state.wi.us

VICE-CHAIR:

Kevin Ruppert (WISC-TV)
W - 271-4321
kruppert@wisctv.com

SECRETARY:

Lloyd Berg (WHPN-TV)
W - 270-5700
lloydberg@earthlink.net

TREASURER:

Stan Scharch (WISC-TV)
W - 271-4321
sscharch@wisctv.com

COMMITTEE APPOINTEES

Program Committee:

Mark Croom	271-1025
Denise Maney	277-8001
Kerry Maki	833-0047
Steve Zimmerman	274-1234

Membership and Past-Chair:

Paul Stoffel
stoffel@vilas.uwex.edu

Sustaining Membership: Fred Sperry

Special Events: Kevin Ruppert

Certification and Education:

Jim Hermanson 836-8340
jmh@execpc.com
Tim Trendt (UW-Platteville)

Frequency Coordination:

Tom Smith W - 263-2174
smithtc@vilas.uwex.edu

SBE National Board Member & Chapter Liaison:

Leonard Charles
W - 271-4321 FAX - 271-1709
lcharles@wisctv.com

January Business Meeting Minutes

The January 1999 meeting of the Society of Broadcast Engineers, Chapter 24, Madison Wisconsin, meet at Rocky Rococo's restaurant on Mineral Point Road in Madison on Wednesday, January 20th. The meeting was called to order by Vice Chair Kevin Ruppert at 6:34 PM.

The December minutes were approved as published in the January newsletter.

Treasurer, Stan Search, reported our check book is balanced and in the black.

Kevin reported 25 sustaining members.

Certification chairman, Jim Hermanson, reported that application for the February certification exams are now closed, but applicants have until March 22nd to apply to take exams at the NAB convention, and that the next locally administered exams will be held in June. Additionally, the SBE has a new certification booklet available.

Leonard Charles reminded everyone that SBE members were eligible for NAB member discounts. Also, the Ennis workshop is scheduled for Wednesday during the NAB convention.

He also reminded us to participate in the National Groundhog Day "shadow" activity, where a young person "shadows" you for the day in order to learn about your career.

A company has claimed patent rights for the EAS protocol and is now in the process of asking broadcasters for royalties for use of the EAS system. The national SBE is looking into this matter. Finally, Leonard is taking over the care and feeding of the SBE Chapter 24 web site.

Kevin announced new business: The UW will be holding a DTV course in late spring. Cost is unknown. Chris Cain has resigned as Chief of WISC-TV and will become Chief of their co-owned radio properties. Erik Barklow was introduced as the new chief of the Woodward radio stations.

Kevin adjourned the business meeting at 6:46pm.

Jim Hermanson then lead the group to the Community Tower for a tour of the new WKOW-DT digital Channel 26 and analog Channel 27 transmitter plant.

Membership Report

The National SBE lists Chapter 24's current membership at 71 members; 40 certified. Chapter 24 mails out 137 newsletters.

Chapter Elections: Call For Nominations!

This is the first call for nominations for interested members to run for a Chapter 24 elected office. In April we will hold elections for Chapter Chair, Vice-Chair, Secretary and Treasurer. If you are interested in running for an office, running for re-election or know of a worthy candidate, please contact any of the nomination committee members.

The committee members are Steve Paugh (Chair) 277-5139 (spaugh@wisctv.com), Jim Hermanson 836-8340 (jmh@execpc.com) or Denise Maney 277-8001 (sloop26@aol.com).

Candidates must be current with their SBE membership and be available for the monthly meetings. A modest time commitment and a desire to serve the chapter are the only qualifications required!

UW Engineering Expo (continued from page 1)

be to inform the general public about digital TV through actual demonstrations, informational literature and collateral technology demonstrations. We would like to have all of the local TV broadcasters take part in a cooperative public display of this new technology.

An update of this project will be given at the February SBE meeting. If you can help in any way with this exhibit contact either myself (spaugh@wisctv.com – 277-5139) or Craig (bluschke@enr.wisc.edu – 265-3976). We are in need of left, center and right speaker systems for the front of the hall, HD playback vtrs, and KU band HDTV down link signals. We would like all of the local TV stations to have a presence at the exhibit.

We will need help in setting up the DTV exhibit the evening before the show. Setup is scheduled for Thursday evening, February 15th, starting at 6 PM. Let us know how you can help. Here's our chance to wow the public with HDTV and showcase the talents of the SBE.

AMATEUR RADIO NEWS

By Tom Weeden, WJ9H

- The American Radio Relay League (ARRL) has filed formal comments in response to the FCC's proposed streamlining of the amateur radio rules, saying that the proposed rulemaking failed to contain "a comprehensive license restructuring proposal or even an overall review of license restructuring." ARRL called on the FCC to adopt the ARRL Board's restructuring plans as the centerpiece of its streamlining efforts. ARRL's plans call for reducing the number of license classes from six to four, and upgrading current Novice and Technician Plus licensees to General class. The FCC was not expected to take action on restructuring at least until sometime this spring.

- Space officials from the US, Russia and several other countries gathered in Houston January 21-27 to continue plans to put amateur radio aboard the International Space Station. The effort ultimately will provide amateur radio with a permanent berth in space aboard the ISS. The so-called "Amateur Radio ISS accommodations meetings" at NASA's Johnson Space Center included a representative from Energia, the Russian space company that is building portions of the ISS. The Houston sessions focused on finalizing the design of the "initial station" ISS ham radio hardware and helped to clarify and firm up the role of multinational amateur radio on the International Space Station.

- TV and electronics pioneer Robert Page Burr, K1MI, died December 31, of complications following heart surgery. Burr once wrote that getting his amateur radio license in 1937 set him on the path of a lifelong interest in Amateur Radio and electronics. After a stint in the Navy during World War II, Burr spent 10 years with Hazeltine Corp and was a key member of the team that developed the US color television standard. He chaired the National Television Standards Committee that eventually persuaded the FCC and the television industry to adopt the NTSC standard. He was 76.

(Excerpts from February 1999 "QST" magazine and "The ARRL Letter")

SCHARCH ELECTRONICS CO.
Small Business Communications
1105 Middleton Street
MADISON, WI 53717-1078
(608) 831-2266 (800) 831-2266

Panasonic
Broadcast & Television Systems Company

HERB VAN DRIEL
Direct Sales Manager
Entertainment Systems Division

Atlanta 1996
The Official Broadcast
Equipment of the
1996 Olympic Games.

1707 N Randall Road
E-Zip: 1-C-3 WI Tel: 608.355.0662 HQ Tel: 847.468.5160
Elgin, IL 61023 WI FAX: 608.355.0663 HQ Fax: 847.468.5161

Division of Matsushita Electric Corporation of America

HARRIS CORPORATION
Communications Sector
Broadcast Systems
1913 Fairoak Road
Naperville, IL USA 60565

HARRIS

TOM HARLE
District Sales Manager
Radio Systems
ISO 9001

telephone 1-630-420-8899
24-hr service 1-217-222-8200
Broadcast Ctr. 1-800-622-0022
facsimile 1-630-420-9171
email: tharle@harris.com

next level solutions www.harris.com

NBC 15
WMTV • MADISON

PHONE
608-274-1515
FAX
608-271-5193

615 FORWARD DRIVE
MADISON, WI 53711

WORKING FOR YOU!
www.nbc15.com feedback@nbc15.com

Broadband Networks Part Twenty-Eight (continued)

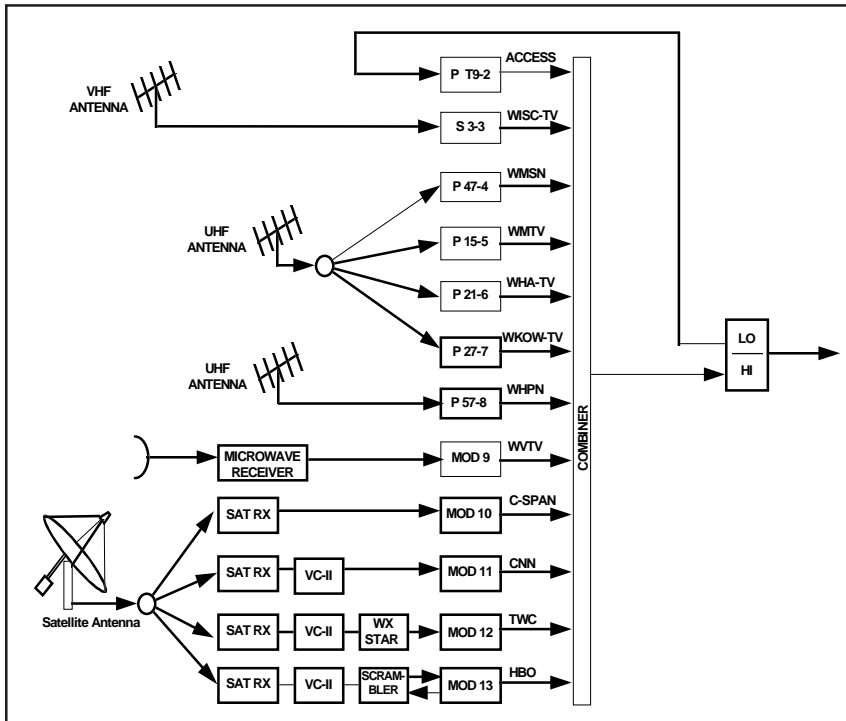

Figure 1. Hypothetical 12-channel headend block diagram.

simple lineup, yet it illustrates a wide variety of NTSC analog equipment.

These channels occupy the same VHF frequencies that are used for off-air broadcasting (see Figure 2). Of course, an actual cable television headend would include channels in the mid-, super-, and hyperbands.

We will discuss this equipment on a channel-by-channel basis starting with Channel 2.

CHANNEL 2: ACCESS PROGRAMMING

Virtually every cable system carries some sort of "access" programming -- local programming originated by local educational institutions, governmental agencies, and individuals. This programming often originates at

locations far removed from the headend: schools, churches, college campuses, municipal buildings, sports venues, etc. Some cable companies maintain dedicated studio facilities for access users; these studios may be located at remote locations as well.

There are many ways to get these access signals back to the headend; the obvious ones are microwave, dedicated cable, and bicycling tapes. But the most common method utilizes the so-called "T" channels located in the subband below Channel 2. These channels are carried upstream over the same cable that carries the combined output of the headend downstream to subscribers (Figure 2).

At our hypothetical headend, the access signal is modulated to NTSC at the remote location and arrives at the

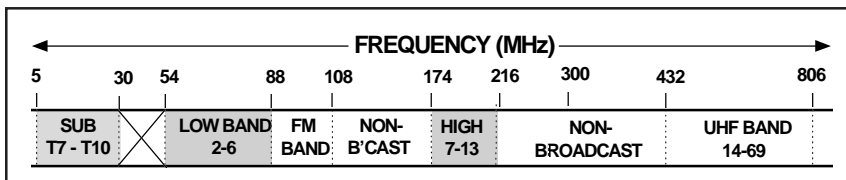
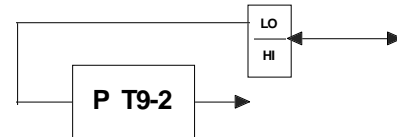

Figure 2. Frequency bands occupied by the hypothetical 12-channel headend. Note that Channel T9 is located in the subband below Channel 2.

headend on Channel T9 (17.75-23.75 MHz). Since it's already an NTSC signal when it arrives at the headend, all we have to do is convert it to Channel 2. For this purpose, we need the following equipment:



- A bandsplitter to separate the subband from the rest of the spectrum. A bandsplitter is simply a band-separation filter that separates the upstream band (5-30 MHz) from the downstream band (54+). Frequencies between 30 and 50 MHz are disrupted in this filter, so they can't be used in either direction.

- A T9-2 processor to convert Channel T9 to Channel 2. A processor amplifies the signal, traps out the lower adjacent aural carrier, filters out all out-of-band signals, and delivers the signal to the combiner at a constant (AGC-controlled) level. The modulation characteristics of the signal, as it was modulated at the remote location, remain intact.

CHANNEL 3: BROADCAST STATION CARRIED ON THE SAME CABLE CHANNEL

This channel carries a VHF station (WISC-TV) received off-the-air and carried on the same cable channel as the broadcast channel. Since it's already an NTSC signal at the desired frequency when it arrives at the headend, all we have to do is amplify it and filter it. For this purpose, we need the following equipment:

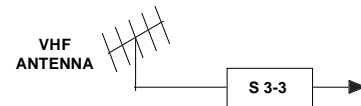

- A receiving antenna. The exact type of antenna to be used depends on a number of obvious factors: the distance between the station's transmitter and the headend; the mounting height of the receiving antenna, and the type of intervening

(continued on next page)

Broadband Networks Part Twenty-Eight (continued)

terrain. We'll discuss off-the-air receiving antennas in detail next month.

- A 3-3 Strip Amplifier. A strip amp amplifies the signal, traps out the lower adjacent aural carrier, filters out out-of-band signals, and delivers the signal to the combiner at a constant (AGC-controlled) level. The modulation characteristics of the signal remain intact. As we noted last month, a strip amp cannot change the frequency of any carrier; however, in this case, no frequency conversion is required.

CHANNELS 4-8: BROADCAST STATIONS CARRIED ON DIFFERENT CABLE CHANNELS

These channels carry UHF stations received off-the-air. Each of these channels must be converted to the proper cable channel; therefore frequency conversions are required. For these signals, we need the following equipment:

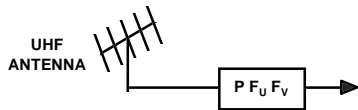

- One or more receiving antennas. Again, the exact type of antennas to be used depends on a number of factors. We'll discuss these factors next month.

- Processors, one for each channel. A processor accepts an NTSC channel at its input and delivers an NTSC channel at its output. Like a strip amp, the modulation characteristics of the signal remain intact. However, unlike a strip amp, a processor can convert a signal from one channel to another. In this case, five processors are used to convert five UHF channels to VHF cable channels. Each processor downconverts the input channel to an intermediate frequency (IF) for processing, then upconverts it to the

desired output channel:

A question might be raised at this point: why couldn't these stations simply be carried on-channel, using strip amps? For a discussion of this question, see TELECOM INDUSTRY NEWS in this *Newsletter*.

CHANNEL 9: BROADCAST STATION RECEIVED BY MICROWAVE

This channel carries a UHF station (WVTV, Milwaukee) received by a microwave link. The audio is carried over the microwave link as a 4.5-MHz frequency-modulated subcarrier superimposed onto the video signal.

This method of signal importation is quite common in the cable industry. Microwave channels in the 13- and 18-GHz bands are allocated in Part 78 of the FCC Rules (Cable Television Relay Service) specifically for signal importation. These channel assignments are identical to the allocations found in Part 74 (Television Broadcast Auxiliary Stations). Franchised cable television operators and broadcast station licensees share these bands on a co-equal basis.

For this signal, the following equipment is required:

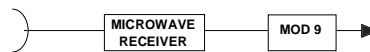

- Microwave antenna and receiver. The output of the receiver is baseband video, with the 4.5-MHz aural subcarrier intact.

- A Channel 9 modulator. A modulator accepts baseband video at its input and delivers an NTSC channel at its output. In this particular case, we select a modulator which can accept the 4.5-MHz aural subcarrier on the

video signal.

With this type of modulator, the modulation characteristics of the visual carrier are determined by the modulator. However, the aural subcarrier is simply passed through with its original modulation intact. In effect, the modulator treats the aural subcarrier just like another video sideband — except that it happens to fall 4.5 MHz above the visual carrier, precisely where we want the aural carrier of the NTSC output signal to fall.

This arrangement maintains the original modulation of the audio signal throughout the entire chain of equipment. The audio signal is modulated once — at the originating broadcast station — and it's never demodulated until it arrives at the subscriber's television set.

This fact may or may not be an advantage. From the cable operator's point of view, it's certainly easier to pass the aural carrier through intact: it's one less adjustment that has to be made. Moreover, less equipment is required, resulting in lower cost.

But it's sometimes a disadvantage too: if two stations modulate their aural carriers at different levels (yes, that really happens!), the difference is immediately obvious to a channel-surfing subscriber.

To solve this problem, it's sometimes necessary to demodulate the aural carrier at the headend and feed it to a modulator which accepts audio at baseband.

CHANNEL 10: AN UNSCRAMBLED SATELLITE SIGNAL CARRIED ON THE BASIC TIER

(continued on page 6)

The logo for WISC-TV Madison CBS Channel 5. It features the CBS eye logo, the text 'WISC-TV' in a bold font, 'MADISON' written vertically, and a large number '5'.

NATIONAL TOWER SERVICE
 Daryl Snowden Paul Jensen
 Office 608-884-8205 Office 608-255-0529
 Fax 608-884-6021 Fax 608-255-2599
 Mobile 608-751-8284 Mobile 608-235-8559

Save Rack Space!
Dual Timer Single rack unit (5" deep)
 Up Timer : Start/Stop & Reset +foot switch
 Clock : Easy Set & Synchro, or external ref
 Read about Smart & Easy features at
<http://members.aol.com/sloop26/maneylog.htm>
maney-logic 608-277-8001

59 59 9 12 59 59

Broadband Networks Part Twenty-Eight (continued)

This channel carries a satellite-delivered signal (C-SPAN) which is received "in the clear"; i.e., not scrambled. It is carried on the so-called "basic" programming tier, available to all subscribers.

For this signal, the following equipment is required:

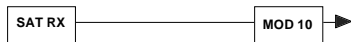

- Satellite antenna. Most cable television headends utilize several fixed receive-only satellite antennas, one for each of the satellites which transmit cable programming.
- Satellite receiver. The output of the satellite receiver is baseband video accompanied by baseband audio.
- A channel 10 modulator. In this particular case, we select a modulator which can accept baseband audio.

CHANNEL 11: A SCRAMBLED SATELLITE SIGNAL CARRIED ON THE BASIC TIER

This channel carries a satellite-delivered signal (CNN) which is scrambled as it is received from the satellite. Like virtually all scrambled programming intended for the cable television industry, the Videocipher II (VCII) scrambling system is used. This signal is carried on the basic programming tier, available to all subscribers.

For this signal, the following equipment is required:



- Satellite antenna and satellite receiver.
- A Videocipher II descrambler.

- A channel 11 modulator. Again, we select a modulator which can accept baseband audio.

CHANNEL 12: THE WEATHER CHANNEL, CARRIED ON THE BASIC TIER

This channel carries The Weather Channel, a satellite-delivered signal which is scrambled as it is received from the satellite. It is carried on the basic programming tier, available to all subscribers.

Unique among cable television program services, The Weather Channel also requires an extra piece of headend equipment: the Weather Star. This PC-based device inserts the local weather forecast every five minutes, and serves as a character generator for other information at other times. The weather forecast is downloaded, from The Weather Channel's studio in Atlanta, over data subcarriers superimposed on the satellite signal. Separate forecasts are downloaded for each of the National Weather Service's 88 regional weather reporting zones.

For this signal, the following equipment is required:

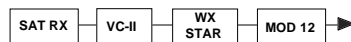

- Satellite antenna and satellite receiver.
- A Videocipher II descrambler.
- The Weather Star.
- A channel 12 modulator. Again, we select a modulator which can accept baseband audio.

CHANNEL 13: A SCRAMBLED SATELLITE SIGNAL CARRIED AS A PAY-PER-CHANNEL SERVICE

This channel carries a satellite-delivered signal (HBO) which is scrambled as it is received from the satellite. It is offered on a "per-per-channel" basis, available only to subscribers who order it separately.

Because this signal is available only to a subgroup of subscribers, some means of controlling access is required. There are many techniques for controlling access; in this case, we have chosen one of the most common methods: scrambling.

There are dozens of ways to scramble an NTSC television signal, but most methods are variations on the same basic technique: sync suppression. This technique involves two steps:

- At the headend, a scrambler suppresses the horizontal sync pulses. Most scramblers act on the visual carrier after it has been modulated. At this point, the signal is inverted: an increase in signal level corresponds to a decrease in picture brightness. A scrambling waveform (typically a pulse chain locked to the horizontal frequency) reduces the level of the entire horizontal blanking interval by a specified amount, typically 5 to 10 dB.
- At the subscriber's television set, the process is reverse: a descrambling waveform (identical to the scrambling waveform, but inverted) reduces the level of the everything *except* the horizontal blanking interval by the same amount.

A subscriber who does not specifically order this channel sees a "scrambled" picture, usually a jumbled mess. Because the sync-separation circuitry in the television set cannot
(continued on next page)



Belden Wire & Cable Company
4218 South Regal Manor Court
New Berlin, Wisconsin 53151

Phone: 414 827 0270
Facsimile: 414 827 0374
Phone Mail: 800 241 7564
Box 2611
<http://www.belden.com>

Jan Reesman
Sales Representative

David Thormodsgaard
Broadcast Sales Engineer
thor@alphavideo.com
(800) 388-0008
(612) 841-3308

7711 Computer Avenue
Edina, MN 55435
(612) 896-9898
FAX (612) 896-9899
www.alphavideo.com

1965 West Ridge Rd.
P.O. Box 51
Cottage Grove, WI 53527
608 / 839-4075
FAX: 608 / 839-4985

COMMUNICATIONS, LTD. • MADISON,
WI ANTENNA SPECIALISTS • TOWER
ERECTORS
RICHARD H. WOOD
President

TOWERS • ANTENNAS
CONSTRUCTION • MAINTENANCE

Broadband Networks Part Twenty-Eight (conclusion)

identify the horizontal sync pulses, it locks onto whatever portion of the active video line extends into the range normally occupied by the sync pulses.

For this signal, the following equipment is required:



- Satellite antenna and satellite receiver.
- A Videocipher II descrambler.
- A scrambler capable of scrambling an NTSC visual carrier.
- A channel 13 modulator. Once again, we select a modulator that can accept baseband audio.

COMBINING THE SIGNALS

Most headend engineers like to organize equipment racks by channel. Thus, in our typical headend, we would find all equipment associated with each channel -- the satellite receiver, the modulator, and any other auxiliary equipment -- grouped

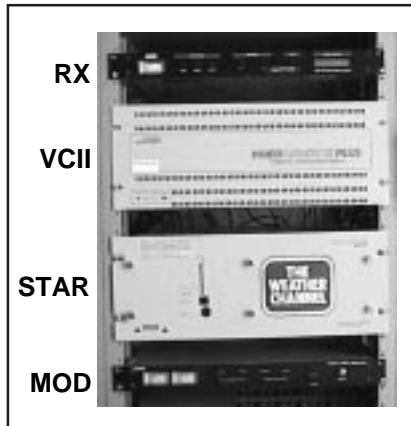
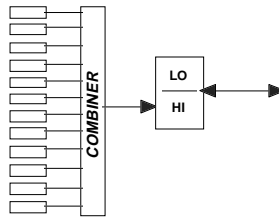

Figure 3. Typical headend equipment grouping for The Weather Channel, including The Weather Star.

together (Figure 3).

The outputs of all of devices -- modulators, processors, and strip amps -- are fed to the combiner where they are combined to form a single electrical signal. This signal is then fed to the HI port of the bandsplitter, where it passes through the bandsplitter and on out to the distribution system:



At many headends, there may be other non-video signals inserted into the combiner as well. In older 12-channel systems (such as the hypothetical headend we've used as an example in this article), two non-video signals were common during the 50s and 60s:

- Allband FM. This signal consisted of the entire FM band (88-108 MHz) picked up by a single antenna, amplified, and processed to remove out-of-band signals. Subscribers received this signal by connecting the CATV drop to their FM tuners. Although more recent headends utilize individually-processed FM signals, the allband technique has a venerable history: was used by many cable systems for many years.
- Pilot. This was a special carrier inserted into the distribution system to serve as a reference for the AGC amplifiers throughout the distribution system. Although it's possible to utilize a visual carrier as an AGC reference, the level of such carriers wasn't always consistent (particularly if it was a broadcast station that went off the air at

night).

Of course, cable systems built within the past dozen years carry many more signals. A modern cable system may carry as many as 100 NTSC television channels, plus digital audio and digital video signals.

But whatever the signal complement, they all end up at the same point: the famous "one wire" that feeds the distribution system.

Next month, we'll continue with the discussion of headends with a look at off-air antenna systems.

LOCAL LEGALS

Compiled by Tom Smith

PROPOSED

**WPKO (FM) Evansville, WI
105.9 MHz**

TBK Communications Corp. seeks to make changes in their transmitting plant and change WPKO'S effective radiated power, Announced February 8, 1999.

GRANTED

**WBKY (FM) Portage, WI 95.9
MHz**

Magnum Communications Inc. was granted a modification to their construction permit to change transmitter location and make changes in the antenna support structure. Announced February 8, 1999.

*From FCC Daily Notices
(www.fcc.gov)*

7847 BIG SKY DRIVE
MADISON, WISCONSIN 53719
(608)833-0047 • FAX(608)833-5055

SONY Kevin Peckham
Account Manager
Broadcast Products Division

Sony Communications Products Company
1200 North Arlington Heights Road
Itasca, Illinois 60143
Telephone (608) 271-3778
(708) 773-6046

Service Center (708) 773-6037
Emer. Tech. Assist. (201) 833-9533
National Parts Center (800) 538-7550

**Thank you to WKOW-TV for
providing copying and folding
facilities for the Chapter 24
newsletter!**

**Thank you to WISC-TV for
maintaining the web server for
the Chapter 24 Web page!**

TELECOM INDUSTRY NEWS

By Neal McLain

WHY DON'T CABLE SYSTEMS CARRY UHF STATIONS ON-CHANNEL? A CASE IN POINT: WXTV vs. CABLEVISION SYSTEMS

As we note in BROADBAND NETWORKS elsewhere in this issue, most UHF stations are converted to VHF cable channels for distribution to subscribers. Sometimes even VHF stations are converted to other VHF channels for distribution.

Why don't cable systems carry all broadcast stations on their native channel number assignments? Wouldn't this simplify headend equipment requirements by allowing strip amps to be used throughout?

A current case pending before the FCC underscores this question: WXTV, a New York Univision affiliate operating on Channel 41, has petitioned the FCC for relief under the FCC's signal-carriage rules. WXTV wants to be carried on its native Channel 41 on cable television systems owned by Cablevision Systems Corporation. Cablevision operates cable systems throughout the New York market; 18 separate headends are affected by this petition.

As this case illustrates, there are several reasons why many cable systems don't carry UHF stations on their native channels. Following is an explanation of the principal reasons.

FREQUENCY DIFFERENCES

Cable channels 14 and above don't operate on the same frequencies as broadcast channels. As we noted in BROADBAND NETWORKS PART 14 (September 1997), cable channel 14 is in

the midband, starting at 120 MHz. From there on up, cable channels operate on completely different frequency assignments.

Even in the 470-806 MHz band, where cable channels overlap the UHF broadcast band, there's a 2-MHz offset between carriers. This explains why it's sometimes possible to receive WMTV on cable channel 66: broadcast channel 15 (476-482 MHz) is just 2 MHz away from cable channel 66 (474-480 MHz).

Since frequency conversion is required even if the broadcast channel and the cable channel are numerically the same, a strip amplifier can't be used.

There's also another reason why strip amps can't be used: strip amps don't work well at higher frequencies (in fact, for this very reason, they don't even exist). This is a manifestation of a well-known fact about frequency-dependent filters: the skirts of a filter affect adjacent frequencies. Thus, a strip amp passes adjacent frequencies that fall within the skirts of its bandpass filter. The higher the center frequency of the bandpass, the wider the skirts, and the more unwanted adjacent frequencies get through.

Of course it would be possible to solve both of these problems by using a processor to convert a UHF station to the same-numbered cable channel. We could, for example, use a processor to convert broadcast channel 41 (632-638 MHz) to cable channel 41 (324-330 MHz).

But there are other reasons for not doing this. Read on.

CPS ACCESS CONTROL

Before exploring this issue, we first

have to understand two FCC terms:

Basic Program Tier. This term defines a tier of programming offered by a cable television operator to its subscribers. It must be provided to all subscribers; it cannot be scrambled; and it must include:

- All broadcast stations except satellite-delivered superstations.
- Certain access programming.
- At the cable operator's option, any other programming.

Cable Programming Service (CPS).

This term includes one or more tiers of optional programming offered by a cable television operator to its subscribers. It is provided only to subscribers who specifically order it, usually at an extra monthly charge. By definition, CPS includes all video programming offered by the cable operator *except*:

- The Basic Program Tier.
- Programming offered on a pay-per-channel basis.
- Programming offered on a pay-per-view basis.

Because WXTV is a local television broadcast station, it has the right, under the FCC's "must-carry" rules, to demand carriage in the Basic Program Tier.

These definitions mean that every cable operator must provide some means of blocking access to CPS so that basic-only subscribers will not receive it. Theoretically, there are two ways to do this:

- Scramble all CPS programming at the headend.
- Insert band-reject filters ("traps") into the drops of basic-only subscribers to block CPS programming.

(continued on next page)



JAMES F. DOHERTY
Traffic Supervisor
Satellite & Video Services

Norlight™
TELECOMMUNICATIONS

275 NORTH CORPORATE DRIVE
BROOKFIELD, WI 53045-5818
414.792.7708 FAX: 414.792.7717
e-mail: jfd@norlight.com



<http://www.CTIinfo.com>
email - cti@CTIinfo.com
Phone - 608-831-4636
Fax - 608-836-1840

VCR Controllers
Character Generators
Satellite Antenna Controllers
Broadcast / Cable Television Consulting



Becky Hilborn
Broadcast Sales
Specialist

40W267 Keslinger Road
LaFox, IL 60147 USA

Phone: (800) 348-5580
(630) 208-2372
FAX: (630) 208-2450
email: becky@rell.com
WWW: <http://www.rell.com>

**Your Tube and
Broadcast Component
Source.**

Telecom Industry News (continued)

As a practical matter, scrambling is out of the question. So-called "cable-ready" sets can't receive scrambled channels, so every CPS subscriber would need a settop converter/descrambler on every television set. Settops precipitate a host of political problems:

- Because channel-selection must be done at the settop, the set's tuner can't be used; thus, the subscriber has to use two remotes.

- Special tuning features like picture-in-picture don't work.

- VCR owners can't record one program while watching another.

The few cable systems that have tried scrambling all CPS channels have faced what was once called a "subscriber rebellion."

So that leaves traps as the only practical solution. But traps are a nightmare too: Every time a subscriber upgrades/downgrades to/from CPS, a technician must be sent to the home to remove/install the trap. On average, each technician trip costs the cable company \$50.

Moreover, traps are available only in certain frequency combinations. Understandably, manufacturers make traps only in combinations which are widely used within the industry.

The closest the cable industry has come to solving these problems is to use the following scheme:

- Place all Basic Program Tier channels in the 54- to 216-MHz range. This block includes 22 cable channels: low band (2-6), high band (7-13), midband (14-22), and (if the frequency plan is HRC and IRC) Channel 1.

- Place all CPS programming on Channel 23 and above.

- Use traps to prevent access to CPS programming.

Because this technique has become widespread within the cable industry, traps designed to reject channels 23 and above are available at reasonable cost.

Cablevision Industries' headends utilize this plan: the Basic Program Tier includes Channels 1-22; CPS programming is assigned to channels 23 and above. Channel 41 falls right in the middle of the CPS block.

With this background in mind, consider the problems Cablevision would face if it agreed to carry WXTV on cable channel 41:

- If it tried to use some combination of traps to pass cable channel 41 without passing other CPS channels (assuming it could even find such a combination), it would probably have to vacate channels 40 and 42 to prevent them from leaking through into the Basic Program Tier.

- If it simply extended the basic tier on up to, say channel 42, and moved all CPS programming to 43 and above (again assuming that it could find the necessary traps), it would face unending subscriber complaints ("why do they keep moving the channels around?"). Moreover, once this precedent was established, WXTV's commercial competitors (in particular, WNJU, Channel 47, also a Hispanic station) might make a similar demand.

- If it tried scrambling all other CPS channels, it would certainly face a rebellion among its CPS subscribers.

STATION REQUEST

There's one more reason why some stations aren't carried on their native channel numbers: sometimes the station requests a different channel.

In a broadcast market with many competing commercial broadcast stations, the station managements often want their signals to be grouped together on cable so that surfing subscribers can find them easily.

Even WXTV realizes this: as an alternative to being placed on cable channel 41, it would accept (perhaps even prefer) a channel in the 1-13 range. However, New York being New York, all of Cablevision's channels in this range are already occupied by signals which, either by FCC rule or local franchise, must be carried in the 2-13 range.

SO WHERE WILL WXTV END UP?

The WXTV case is now in the hands of the FCC. Cablevision has offered to carry WXTV on one of the midband channels (14-22) which fall in the Basic Service Tier; however, it has refused to carry it on cable channel 41. Cablevision's chairman, Charles Dolan, has stated that it would cost \$4 million to accommodate WXTV's request.

Univision Communications, Inc., WXTV's parent company, has continued to request Channel 41. Univision's president, Henry Cisneros (the former HUD secretary) asserts that Cablevision's cost figures are "unsubstantiated and undocumented."

In the end, Cablevision may win by default: according to Multichannel News, Cisneros is under indictment for allegedly concealing from the FBI \$250,000 in payments to his former mistress.

 HEWLETT PACKARD	<p>Jon S. Gedymin Video Sales Manager Midwest Region</p> <p>Hewlett-Packard Company 250 North Patrick Boulevard, Suite 100 Brookfield, Wisconsin 53045-9945</p> <p>800/477-6111 Ext. 2263 Fax 414/569-0966</p> <p>Internet: jon_gedymin@hp.com</p>
--	---

<p>Chapter 24 World Wide Web Site http://www.sbe24.org</p>  <p>Steve Paugh is the editor for the HTML Version of this Newsletter, available monthly on the SBE Chapter 24 web page.</p>

	
<p>Jim Rigsby Account Executive Private, State, Local Government</p>	<p>Alcatel Network Systems 2800 West Higgins Road Suite 825 Hoffman Estates, IL 60195 Tel: (847) 490 2076 Fax: (847) 490 2073 E-mail: james_a_rigsby@aud.alcatel.com</p>



FCC Rulemakings

Compiled by Tom Smith

PROPOSED RULES

ET Docket No. 99-34; FCC 99-8 An Industry Coordination Committee System for Broadcast Digital Television Service

The FCC has issued a Notice of Rule Making request comment on the creation of a coordination committee to assist in the implementation of the digital television system. The FCC proposes that the television broadcast industry establish a coordination committee, similar to that used by the land mobile industry. The proposed coordination committee would process and evaluate proposals for changes in both DTV and NTSC station transmission facilities and changes in the DTV Table of allotments from all TV broadcasters including low-power translator stations.

The FCC is asking if the coordination by the proposed committee should be voluntary or mandatory. If the coordination by the industry committee system is mandatory, it would replace the existing rules for voluntary negotiation of DTV allotments and facility changes.

The proposed coordination system would consist of a number of regional committees under the umbrella of a national coordinating organization. The national coordinator would manage the system, maintain a national database, produce procedures and software systems and monitor the regional committees. The committees would be required to process requests in the order received and in a timely matter and maintain records of their actions. The committees could charge a fee to cover their costs.

Comments are due March 29, 1999, and replies due April 28, 1999. This notice was adopted on January 28, 1999 and released on February 3, 1999. It was published in the FEDERAL REGISTER on February 9, 1999 on pages 6296-6300.

FINAL RULEMAKINGS

CS Docket No. 98-201; FCC 99-14 Satellite Delivery of Broadcast

Network Signals under the Satellite Home Viewer Act

The FCC has adopted rules that create a method for measuring signal strength at an individual household. These rules are in response to the Satellite Home Viewer Act and the need to determine if a viewer is "unserved" by a network signal and eligible to receive network signals via home satellite dish.

To determine the signal level at an individual home, either actual measurements or prediction of the signal level can be used. If measurements are used, a tuned dipole must be used with a cluster of five measurements taken as close to the location of the likely location of the homeowner's antenna.

If the signal is determined by prediction, then the Individual Location Laughingly-Rice Model must be used with terrain elevation considered every 1/10 of a kilometer, a confidence variability of 50%, and error codes appearing on the prediction shall be ignored with the predicted value accepted or measurements used. Land use (buildings) and land cover (vegetation) shall be included when an accurate method is developed for their use in the prediction. There are a number of specifics concerning equipment, measurement methods and use of data in the use of either measurement or prediction that need to be considered to meet FCC requirements.

The FCC also determined that an standard antenna height is assumed to be 20 feet above ground for a one story home and 30 feet above ground for a two story home. The method for determining Grade B signal coverage for FCC license information remains the same as in the past.

This action was taken on February 1, 1999 and released on February 2, 1999. It was published in the Federal Register on February 21, 1999 on Pages 7113-7127. Full Text is available from the FCC on their web site.

From the FEDERAL REGISTER
(www.access.gao.gov) and FCC Press
Release (www.fcc.gov).

FCC PROPOSES LOW POWER FM SERVICE

By Tom Smith

In response to a number of petitions and a large number of comments in a Notice of Inquiry concerning those petitions, the FCC has issued a Notice of Proposed Rulemaking proposing the creation of a low power FM service.

The FCC is proposing two classes of low power FM stations. The two classes of stations are LP1000 and LP100. A LP1000 station would operate at 1000 watts at 60 meters (197 ft) with primary status like existing FM stations. Primary status means that the station cannot be bumped off the air by any new or upgrade full power station. These stations would follow most or all of the rules that apply to existing FM stations. The 1 mV/m contour would be located about 8.8 miles.

The LP100 station would operate with 100 watts at 30 meters (98 ft) with secondary status. Secondary status means that a LP100 station would have to leave the air to make room for new or upgraded full power FM stations. The 1 mV/m contour would be at 3.5 miles.

The FCC is also asking for comments on whether it should consider the establishment of micropower stations operating at 1 to 10 watts at 30 meters with 1 mV/m contours of 1 to 2 miles. These stations would be secondary to all other stations.

The FCC is proposing that minimum separations between full power and the new low power FM stations and the separations between low power stations be based on mileage separation table instead of the contour overlap method as used by low power TV which the FCC found burdensome.

The biggest technical issue the FCC is considering in the creation of low power FM is the 2nd and 3rd adjacent channel standards. The FCC

(continued on next page)

Low Power FM (continued)

is proposing that only the 1st adjacent channel be protected between low power FM stations with no protection between low power station for 2nd and 3rd adjacent channels. The FCC is asking for comment on the allowing of low power FM stations to operate without regard to the 2nd and 3rd adjacent channel protection to full power stations. The promoters of the in-band-on-channel digital systems have already express opposition to that proposal saying it would be harmful to their proposed digital broadcasting system. There are a number of tables in the notice including the mileage separation tables and separate Excel spreadsheets that gives the number of potential stations in various sized cities from the largest cities to cities as small as 50,000.

The FCC has proposed a number of ownership limitations including limiting the ownership of one station per community and no ownership of low power FM stations if one owns a full power station. Low power stations could not be run under local marketing agreements or as repeaters or translators of a full power station. One ownership limitation that was proposed that one could own a low power FM for one license term only. Another ownership question that the FCC raised is if the commercial operation should be allowed on stations in the non reserved band or if all low power stations should be nonprofit operations.

Comment on application processing is also sought. An electronic filing system is proposed with programs to analyze potential conflicts. The FCC is asking if applications should be processed on a first-come first-served basis or if they should use a window system for filing applications. The use of auctions for license selection was also discussed.

The FCC adopted this action on January 28th with a 4 to 1 vote with Commissioner Furchtgott-Roth dissenting on a number of points. The other Commissioners while endorsing the proposal still express some concerns about potential interference

problems. Comments are due on April 12th and replies on May 12th. The Docket number is MM Docket No. 99-25; R-9208;R-9242 and the title is Creation of a Low Power Radio Service.

Besides the opposition from the promoters of the in-band on-channel digital systems, the National Association of Broadcasters has started to promote their opposition to the new service.

From the FCC Notice and Press Release and BROADCASTING and CABLE

EAS Red Envelope Eliminated

By Gary Timm, Broadcast Chair, Wisconsin EAS Committee

The FCC has eliminated the use of the EAS Red Envelope Authenticator List, effective 1/1/99. No Red Envelopes were sent out for 1999, and stations are no longer required to have one. Now, any National EAS Alert received through proper channels is considered to be valid. From now on, no "Authenticator Code Words" will be sent with a National EAS Alert.

From the FCC Public Notice: "Part 11 of the Commission's EAS rules will be amended to delete use of the authenticator lists. Also, the procedures in the EAS AM/FM and TV Handbooks will be revised to reflect that the use of authenticator lists is discontinued."

Per Frank Lucia at the FCC EAS Office, no versions of the updated EAS Handbooks are yet available, on-line, or elsewhere.



BCS
Wireless

- Tower Construction
- Maintenance
- HDTV upgrades

John W. Crooks (608) 527-5670
Vice President

Over 40 years of service to the Broadcasters.

CHAPTER 24 SUSTAINING MEMBERS

WELCOM TO OUR NEW SUSTAINING MEMBER:

Alcatel USA

RECENT RENEWALS:

**Harris Corporation
Teleport Minnesota
Tektronix
WMTV-TV 15**

THANKS TO ALL OUR SUSTAINING MEMBERS:

**Alpha Video
BCS Wireless
Belden Wire and Cable
CTI
Clark Wire and Cable
Hewlett-Packard
Louth Automation
maney-logic
National Tower Service
Norlight Telecommunications
Panasonic Broadcast
Richardson Electronics
Roscor Wisconsin
Scharch Electronics
Skyline Communications
Sony Broadcast
Token Creek Productions
Video Images
WISC-TV 3
WKOW-TV 27
WMSN-TV 47**



WKOW
Madison

5727 Tokay Boulevard
Madison, Wisconsin 53719

(608) 274-1234
Fax: (608) 274-9514

Jim Pianowski Tektronix, Inc.
Central Regional Manager **Video and Networking Division**
Western Area 515 West Algonquin Road, Ste 100
Arlington Heights, Illinois 60005
james.j.pianowski@tek.com
800 458-7587 ext. 6797 Voice Mail
847 431-5755 Mobile
847 381-4738 Home
800 452-1368 Pager

847 734-6797
847 364-7582 Fax

Tektronix



Society of Broadcast Engineers, Inc. 8445 Keystone Crossing Suite 140 Indianapolis, IN 46240



Office (317) 253-1640 Fax (317) 253-0418 Job Line (317) 253-0474 http://www.sbe.org



KURT SCHINI REGIONAL SALES MANAGER CENTRAL U.S./CANADA

271 MOUNTAIN WAY, CHANHASSEN, MN 55317 PHONE (612) 401-8658 FAX (612) 401-8659 PAGER (888) 415-2791 e-mail LouthKS@compuserve.com



Thomas Sibenaller Sales Representative

Roscor Wisconsin 2610 Van Loon Road La Crosse, WI 54601 Phone: 608-784-6702 FAX: 608-785-0505 e-mail: sales@rosacor.com



CLARK WIRE & CABLE

1355 ARMOUR BOULEVARD MUNDELEIN, IL 60060-4401 (800) CABLE-IT - (847) 949-9944 FAX: (847) 949-9595 E-MAIL: SALES@CLARKWC.COM WWW.CLARKWC.COM



Mark Durenberger General Manager

90 South 11th Street Minneapolis, MN 55403

Office (612) 330-2433 Fax (612) 330-2603 e-mail durenberger@teleportmn.com



John Salzwedel

3893 Terrace Circle DeForest, Wisconsin 53532 Office: (608) 238-7575 Fax: (608) 238-4955 Web Page: www.tokencreek.com E-Mail: tcp@titis.com



VIDEO IMAGES

Milwaukee Madison Chicago Indianapolis

Video Images, Inc. 2137 S. Stoughton Road • Madison, WI 53716 Phone:(608) 221-8888 • FAX:(608)221-9252 Internet: http://www.videoimages.com/

SBE

SBE Chapter 24 Newsletter 5174 Anton Drive #15 Madison, WI 53719-4201



FIRST CLASS MAIL

Newsletter edited on Pagemaker 5.0 by: Mike Norton

Contributors this month: Lloyd Berg, Neal McLain, Steve Paugh, Tom Smith, Gary Timm, and Tom Weeden.

Thanks to Leonard Charles for his work on the Chapter 24 WWW page.

© 1999 by SBE Chapter 24, Inc. Views expressed herein do not necessarily reflect the official positions of the Society, its officers, or its members. SBE Chapter 24, Inc. regrets, but is not liable for, any omissions or errors. The Chapter 24 Newsletter is published twelve times per year. Other SBE Chapters are permitted to use excerpts if attributed to the original author, sources, and SBE Chapter 24.

FEBRUARY MEETING and PROGRAM



**Society of Broadcast Engineers
CHAPTER 24 MADISON, WISCONSIN
Tuesday, February 23, 1999**

Year 2000 Preparations

Join your fellow broadcast engineers for a round table discussion of what area broadcasters are willing to admit they're doing in preparation for possible problems related to the Year 2000 transition. Is *your* facility ready? Will it be? Do you think anything will happen? Bring your facts and opinions, and let's have a lively discussion about broadcasters and Y2K.

Afterward see WNWC's new digital on-air console, and tour the station if you'd like.

**Dutch Treat Dinner
at J.T. Whitney's
674 S. Whitney Way
at 5:30pm**

**Meeting and Program
at WNWC-AM/FM
5606 Medical Circle
at 7:00pm**

Visitors and guests are welcome at all of our SBE meetings!

Program Committee:

**Kerry Maki
833-0047**

**Denise Maney
277-8001**

**Steve Zimmerman
274-1234**

**Mark Croom
271-1025**

SBE's Short Circuits - February 1999

*By John Poray, CAE
SBE Executive Director*

MILLENNIUM PROJECT OFFERS OPPORTUNITY TO GET LAPSED CERTIFICATION BACK

SBE will offer a limited time opportunity to those who have let their SBE Certification drop. Dubbed, the Millennium Certification Project," because it will continue from now until December 31, 1999, the program will allow anyone who has let his or her SBE Certification drop to apply for certification reinstatement without taking another exam. Applicants are required to complete a two-page application and submit it to the National Certification Committee explaining how they have maintained their knowledge and enhanced their experience in broadcast technology over the past several years. Applications will be reviewed by members of the National Certification Committee, who will apply essentially the same recertification criteria that would be applied to non-lapsed certification holders. Past holders of Certified Broadcast Technologist, Certified Broadcast Engineer and Certified Senior Broadcast Engineer certifications are eligible. Past holders of Certified Professional Broadcast Engineer may also apply but will recertify at the Senior level. Following recertification at the Senior level, former CPBE's may apply for certification at the CPBE level. A flat \$99 fee is required with the application. It does not include membership in SBE, which is optional, though very much encouraged. Non-members wishing to become a member of SBE should include an additional \$55 (one year's membership dues) with their application. To get a Millennium Certification Project application, see your Chapter Certification Chairman or contact Linda Godby-Emerick, Certification Director at the SBE National Office, at (317) 253-1640 or lgodby@sbe.org.

ENNES WORKSHOPS PART OF NAB BROADCAST ENGINEERING CONFERENCE

For the third year, the Ennes Workshops will be part of the NAB Broadcast Engineering Conference, held in Las Vegas as a part of the NAB '99 Spring Convention. This year, the Workshops will be held on Wednesday, April 21, and will be the "radio/audio" track for that day. Admission to the Workshops is included with Full Conference Registration. Ennes Education Committee chairman, Richard A. Farquhar, CPBE, will moderate the sessions. Sessions will run from 9:00 am to 4:00 pm, with a break at noon for the annual NAB Technology Luncheon. Session topics will include, "The 2000 Engineer" by Paul McLane, editor of "Radio World," "AES Audio for Broadcast Systems," by Gary Stephens of Leitch, Inc.; "Computers-The Radio Connection," by Chris Scherer, editor of "BE Radio". Scherer will also present, "Technology in Transition," which will be followed by "Building a Digital Station," by David Baden, Director of Technical Operations for Radio Free Asia.

SBE MEETINGS AND EVENTS SCHEDULED FOR NAB '99

SBE has announced its schedule of meetings and events to be held in conjunction with the NAB Spring Convention in Las Vegas, April 17-22. Saturday, April 17 Certification Committee Meeting, Royal Salon, Las Vegas Hilton Hotel, 6:30 pm Sunday, April 18 Board of Directors Meeting, Embassy Salon, Las Vegas Hilton Hotel, 8:30 am Monday, April 19 Frequency Coordinators Meeting, Conference Room 13, Las Vegas Hilton Hotel, 1:30 pm Ennes Trust Meeting, Conference Room 14, Las Vegas Hilton Hotel, 3:00 pm Tuesday, April 20 Certification Exams, Conference Room 13, Las Vegas Hilton Hotel, 9:00 am Membership/Chapter Chairmen Meeting, Room N250, Las Vegas Convention Center, 5:30 pm. The NAB Broadcast Engineering Conference, co-presented by SBE and NAB, will be held Sunday through Thursday. The Ennes Workshops will be one of the conference session tracks offered on Wednesday (not on Saturday as was done the past two years). Admittance to the Ennes Workshops is included with Full Convention Registration. There is no additional fee. Exhibit Only registrants will not have access to the Workshops.

MEMBERS GET DISCOUNTED NAB REGISTRATION

Once again, SBE members get a great discount on registration for the NAB Convention in Las Vegas. SBE members will get the NAB Member rate off the full conference fee. This is a savings of \$330, Six times the cost of one-year of SBE membership! If you haven't received registration material direct from NAB, call them at (800) 424-8806 and request that one is sent to you.

NOMINATIONS COMMITTEE ANNOUNCED, CANDIDATES SOUGHT

SBE President Ed Miller, CPBE, has announced the names of members appointed to serve on the 1999 SBE Nominations Committee. Serving as chairman will be past SBE National President, Richard A. Farquhar, CPBE of RAF Associates in Canal Winchester, Ohio. Serving with Rick will be current member of the Board, Larry Wilkins, CPBE of Cumulus Radio in Montgomery, Alabama and Joseph Snelson, Jr., CPBE of Meredith Broadcasting in Fairway, Kansas. The Nominations Committee has the responsibility of identifying and presenting qualified candidates for national officer and board positions. The Nominations Committee is seeking candidates to run for office this summer. Candidates must be Regular, Senior or Life SBE members in good standing and hold a current SBE engineering certification. Board members serve terms of two years and are expected to attend two full Board meetings each year; the spring meeting held in conjunction with the NAB Spring Convention, and the fall meeting, held during the SBE National Meeting. Terms for officers are one year. Officers are expected to attend the two full meetings of the Board, plus two Executive Committee meetings, held in between Board meetings during the winter and summer. All those who serve must be willing to cover their own travel expenses. Members of the Board are usually appointed to serve as chairman of a committee. If you are interested in being nominated for a national elective position by the Nominations Committee, or would like to discuss the idea further, contact any of the members of the committee before March 8th. Rick Farquhar - rick@rafassociates.com; Larry Wilkins - wilkins@wlwi.com or Joe Snelson - jsnelson@kctv.com.